

REPRESENTATIONS FROM MATRIX VARIETIES, AND FILTERED RSK

ABIGAIL PRICE, ADA STELZER, AND ALEXANDER YONG

ABSTRACT. Matrix Schubert varieties [Fulton 92] carry natural actions of Levi groups. Their coordinate rings are thereby Levi-representations; what is a combinatorial counting rule for the multiplicities of their irreducibles? When the Levi group is a torus, [Knutson–Miller ’04] answers the question. We present a general solution, a common refinement of the multigraded Hilbert series, the Cauchy identity, and the Littlewood–Richardson rule. Our result applies to any “bicrystalline” algebraic variety; we define these using the operators of [Kashiwara ’95] and of [Danilov–Koshevoi ’05, van Leeuwen ’06]. The proof introduces a “filtered generalization of the Robinson–Schensted–Knuth correspondence.

1. INTRODUCTION

1.1. Overview. Fix finite-dimensional vector spaces V and W over \mathbb{C} ; $\mathbf{GL} = GL(V) \times GL(W)$ acts naturally on the tensor product $V \boxtimes W$, as does the maximal torus $\mathbf{T} = T(V) \times T(W)$. These groups then act on the coordinate ring $\text{Sym}^*(V \boxtimes W)$ and the *Cauchy identity* equates the \mathbf{T} -weight space decomposition of this \mathbf{GL} -module to its decomposition into \mathbf{GL} -irreducibles. This identity is equivalent to *Schur–Weyl duality* of irreducible representations of general linear and symmetric groups, and to the *First Fundamental Theorem of Invariant Theory for GL_n* (see, e.g., [15]). In symmetric function theory it implies the existence of a bijection between nonnegative integer matrices and pairs of semistandard Young tableaux, which is realized by the *Robinson–Schensted–Knuth correspondence* (RSK).

We propose a two-fold generalization. In one direction, replace $GL(V)$ with the *Levi subgroups* L associated to parabolic subgroups $P \subseteq GL(V)$. These Levi groups give an “interpolation” of reductive groups between $GL(V)$ and $T(V)$; if $P = GL(V)$ then $L = GL(V)$ and if $P = B$ is a Borel subgroup containing $T(V)$, then $L = T(V)$. We replace \mathbf{GL} with $\mathbf{L} = L(V) \times L(W)$. The second direction lifts from (multi)linear algebra to algebraic geometry: replace the affine space $V \boxtimes W$ with a variety $\mathfrak{X} \subseteq V \boxtimes W$ on which \mathbf{L} acts rationally. Hence \mathbf{L} acts on the coordinate ring $\mathbb{C}[\mathfrak{X}]$. In commutative algebra, the \mathbf{T} -character is the $(\mathbb{Z}^m \times \mathbb{Z}^n$ -multigraded) *Hilbert series* of $\mathbb{C}[\mathfrak{X}]$. Writing this Hilbert series in terms of irreducible characters of \mathbf{L} *abstractly* generalizes the Cauchy identity.

Concretely, we generalize the Cauchy identity by introducing a “filtered” refinement of RSK. Kashiwara’s *crystal operators* (see, e.g., [3]) “pull-back” to *bicrystal operators* on the set $\text{Mat}_{m,n}(\mathbb{Z}_{\geq 0})$ of nonnegative integer matrices, by work of Danilov–Koshevoi [5] and of van Leeuwen [30]. The Hilbert series of $\mathbb{C}[\mathfrak{X}]$ is the generating series of torus weights for a basis of *standard monomials*. Identifying $V \boxtimes W$ with the space $\text{Mat}_{m,n}$ of $m \times n$ complex matrices, this basis is encoded by $\text{Mat}_{m,n}(\mathbb{Z}_{\geq 0})$. Define $\mathfrak{X} \subseteq \text{Mat}_{m,n}$ to be *\mathbf{L} -bicrystalline* if it is \mathbf{L} -stable and its standard monomial basis is closed under the bicrystal operators. Our main result is that for such \mathfrak{X} , filtered RSK determines multiplicities of the irreducibles in the \mathbf{L} -module $\mathbb{C}[\mathfrak{X}]$.

Date: March 15, 2024.

Questions about *determinantal varieties* motivate this work. The space $\mathfrak{X} = \mathfrak{X}_k$ of rank $\leq k$ matrices in $\text{Mat}_{m,n}$ appears in invariant theory, representation theory, and algebraic geometry; see, e.g., [12, 25, 31]. Much has been achieved in understanding them, including their Hilbert series. Each \mathfrak{X}_k is GL -bicrystalline. More generally, our main source of L -bicrystalline varieties, for various $\text{L} \supseteq \text{T}$ are $\mathfrak{X} \subset \text{Mat}_{m,n}$ that are $\mathbf{B} = B_m \times B_n$ stable, where $B_m \leq \text{GL}_m$ and $B_n \leq \text{GL}_n$ are the Borel groups of lower triangular matrices. These (possibly reducible) \mathbf{B} -stable varieties include the *matrix Schubert varieties* of Fulton [8]; our main results are new even for these cases.

This paper initiates our use of the L -actions on matrix Schubert varieties to attack the open problem of determining their Betti numbers and minimal free resolutions, extending the *Kempf-Lascoux-Weyman complexes* [31]. Much of this homological information is encoded in the L -irreducible decomposition of their coordinate rings, our focus here. Our results simultaneously generalize the Cauchy identity, the Littlewood-Richardson rule, and the Knutson–Miller Hilbert series formula for matrix Schubert varieties [18, 17].

1.2. Filtered RSK. In the language of symmetric polynomials, the *Cauchy identity* states

$$(1) \quad \prod_{\substack{1 \leq i \leq m \\ 1 \leq j \leq n}} \frac{1}{1 - x_i y_j} = \sum_{\lambda} s_{\lambda}(x_1, \dots, x_m) s_{\lambda}(y_1, \dots, y_n);$$

where λ is an integer partition and $s_{\lambda}(t_1, \dots, t_k)$ is the *Schur polynomial*, i.e., the generating series for *semistandard Young tableaux* (SSYT) of shape λ with entries in $[k] := \{1, 2, \dots, k\}$:

$$(2) \quad s_{\lambda}(t_1, \dots, t_k) := \sum_T \prod_{i=1}^k t_i^{\#\text{in } T}.$$

To prove (1) combinatorially, one defines a map RSK that sends a matrix $M \in \text{Mat}_{m,n}(\mathbb{Z}_{\geq 0})$ to a pair of SSYT. This map uses the *row word* and *column word* of M .

Definition 1.1. The *row word* of a matrix $M = [m_{ij}] \in \text{Mat}_{m,n}(\mathbb{Z}_{\geq 0})$, denoted $\text{row}(M)$, records m_{ij} copies of the row index i for each entry m_{ij} of M . The entries are read along columns top-to-bottom, left to right. The *column word* $\text{col}(M)$ is formed by recording m_{ij} copies of the column index j for each entry m_{ij} of M . The entries are read across the rows in English reading order.

Example 1.2. If $M = \begin{bmatrix} 0 & 1 \\ 2 & 3 \end{bmatrix}$ then $\text{row}(M) = 221222$ and $\text{col}(M) = 211222$.

In Section 3 we recall the *reading word* of a semistandard tableau T , denoted $\text{word}(T)$ (Definition 3.3), the *Knuth equivalence* relation \sim_K on words (Definition 3.5), and the fact that the Knuth equivalence class of any word contains $\text{word}(T)$ for exactly one semistandard Young tableau T (Theorem 3.6). With these notions, it is convenient to phrase the traditional RSK correspondence in this manner:

Definition 1.3 (RSK correspondence). Let $M \in \text{Mat}_{m,n}(\mathbb{Z}_{\geq 0})$, and P and Q be the unique SSYT with $\text{row}(M) \sim_K \text{word}(P)$ and $\text{col}(M) \sim_K \text{word}(Q)$. Define $\text{RSK}(M) = (P|Q)$.

Although non-obvious from Definition 1.3, RSK gives a bijection between matrices $M \in \text{Mat}_{m,n}(\mathbb{Z}_{\geq 0})$ and pairs $(P|Q)$ of semistandard tableaux of the same shape λ . Grouping monomials corresponding to M according to the shape of the tableaux in $\text{RSK}(M)$ proves

the classical Cauchy identity (1). This shape-symmetry of RSK is not assumed, nor even true, in what follows.

We will generalize the proof of (1) by refining RSK. This refinement uses the *filtration* of a word w in $[m]$ for a sequence of nonnegative integers $\mathbf{I} = \{0 = i_0 < \dots < i_r = m\}$.

Definition 1.4. The \mathbf{I} -filtration of a word w is the tuple of words $\text{filter}_{\mathbf{I}}(w) = (w^{(1)}, \dots, w^{(r)})$, where $w^{(k)}$ is the subword of w consisting of all letters in the interval $[i_{k-1} + 1, i_k]$.

Main definition 1.5 (Filtered RSK). Let $M \in \text{Mat}_{m,n}(\mathbb{Z}_{\geq 0})$ and fix two integer sequences

$$(3) \quad \mathbf{I} = \{0 = i_0 < \dots < i_r = m\} \text{ and } \mathbf{J} = \{0 = j_0 < \dots < j_s = n\}.$$

Define $\text{filterRSK}_{\mathbf{I},\mathbf{J}}(M) = (\underline{P}|\underline{Q}) := (P^{(1)}, \dots, P^{(r)}|Q^{(1)}, \dots, Q^{(s)})$, where $P^{(a)}$ and $Q^{(b)}$ are the unique SSYT with $P^{(a)} \sim_K \text{filter}_{\mathbf{I}}(\text{row}(M))^{(a)}$ and $Q^{(b)} \sim_K \text{filter}_{\mathbf{J}}(\text{col}(M))^{(b)}$, respectively.

Using *row insertion* one can algorithmically compute the tableaux appearing in the definitions of RSK and filterRSK ; see Section 3.

Example 1.6. Let $\mathbf{I} = \{0, 1, 3\} = \mathbf{J}$ and let $A = \begin{bmatrix} 0 & 2 & 0 \\ 2 & 1 & 0 \\ 2 & 0 & 0 \end{bmatrix}$. Then $\text{row}(M) = 2233112$ and $\text{col}(M) = 2211211$, so

$$\text{filter}_{\mathbf{I}}(\text{row}(M)) = (11, 22332) \text{ and } \text{filter}_{\mathbf{J}}(\text{col}(M)) = (1111, 222).$$

Now, consider the tuple of tableaux

$$(P^{(1)}, P^{(2)}|Q^{(1)}, Q^{(2)}) = \left(\begin{array}{c|c} \boxed{1} \boxed{1} & \boxed{2} \boxed{2} \boxed{2} \boxed{3} \\ \hline & \boxed{3} \end{array} \middle| \begin{array}{c|c} \boxed{1} \boxed{1} \boxed{1} \boxed{1} & \boxed{2} \boxed{2} \boxed{2} \end{array} \right).$$

The reading words of these tableaux are $(11, 32223|1111, 222)$. Since $32223 \sim_K 22332$, $\text{filterRSK}(M) = (P^{(1)}, P^{(2)}|Q^{(1)}, Q^{(2)})$.

1.3. The main result. Let $GL_k = GL_k(\mathbb{C})$ be the general linear group of invertible $k \times k$ matrices. Then $\mathbf{GL} := GL_m \times GL_n$ acts on $\text{Mat}_{m,n}$ by row and column operations, i.e., if $(p, q) \in \mathbf{GL}$ and $M \in \text{Mat}_{m,n}$,

$$(4) \quad (p, q) \cdot M = p^{-1}M(q^{-1})^T.$$

The coordinate ring $\mathbb{C}[\text{Mat}_{m,n}]$ is thus endowed with a \mathbf{GL} -module structure: if $(p, q) \in \mathbf{GL}$, $M \in \text{Mat}_{m,n}$ and $f \in \mathbb{C}[\text{Mat}_{m,n}]$ then

$$(5) \quad ((p, q) \cdot f)(M) := f(pMq^T).$$

If f is a degree- d polynomial then so is $(p, q) \cdot f$ for all $(p, q) \in \mathbf{GL}$, so in fact the grade- d component $\mathbb{C}[\text{Mat}_{m,n}]_d$ of $\mathbb{C}[\text{Mat}_{m,n}]$ is a finite-dimensional representation of \mathbf{GL} . Any finite-dimensional representation of GL_k is a direct sum of irreducible *Weyl modules* V_λ , where λ is a partition with at most k rows, i.e., $\ell(\lambda) \leq k$. The irreducible representations of \mathbf{GL} are $V_\lambda \boxtimes V_\mu$ and there exist $c_{\lambda|\mu} \in \mathbb{Z}_{\geq 0}$ indexed by partition-pairs $(\lambda|\mu)$ such that

$$(6) \quad \mathbb{C}[\text{Mat}_{m,n}]_d \cong_{\mathbf{GL}} \bigoplus_{\lambda|\mu: \ell(\lambda) \leq m, \ell(\mu) \leq n} (V_\lambda \boxtimes V_\mu)^{\oplus c_{\lambda|\mu}}.$$

The \mathbf{T} -character of $\mathbb{C}[\text{Mat}_{m,n}]$ is the lefthand side of (1). Since the character of $V_\lambda \boxtimes V_\mu$ is $s_\lambda(x_1, \dots, x_m) s_\mu(y_1, \dots, y_n)$, it follows that there is an identity of polynomials

$$\prod_{\substack{1 \leq i \leq m \\ 1 \leq j \leq n}} \frac{1}{1 - x_i y_j} = \sum_{\lambda|\mu} c_{\lambda|\mu} s_\lambda(x_1, \dots, x_m) s_\mu(y_1, \dots, y_n).$$

Treating the lefthand side as the generating series for nonnegative matrices, and using the definition (2) in terms of semistandard Young tableaux, one deduces from RSK that $c_{\lambda|\mu} = 0$ unless $\lambda = \mu$, in which case $c_{\lambda|\lambda} = 1$, in agreement with (1).

We now generalize (1) and the proof just outlined to a type of (possibly reducible) variety $\mathfrak{X} \subseteq \text{Mat}_{m,n}$. We use reductive groups that “interpolate” between \mathbf{T} and \mathbf{GL} :

Definition 1.7. Let $\mathbf{L}_{\mathbf{I}|\mathbf{J}} = L_{\mathbf{I}} \times L_{\mathbf{J}} \leq \mathbf{GL}$, where $L_{\mathbf{I}} = GL_{i_1-i_0} \times GL_{i_2-i_1} \times \dots \times GL_{i_r-i_{r-1}}$.

By subgroup restriction, each $\mathbf{L}_{\mathbf{I}|\mathbf{J}}$ acts on $\text{Mat}_{m,n}$ via (4). A variety $\mathfrak{X} \subset \text{Mat}_{m,n}$ is $\mathbf{L}_{\mathbf{I}|\mathbf{J}}$ -stable if this action fixes \mathfrak{X} .

Our technical condition on \mathfrak{X} concerns a compatibility of Gröbner basis theory with Kashiwara’s crystal basis theory. Identify $\mathbb{C}[\text{Mat}_{m,n}] \cong \mathbb{C}[z_{ij}]_{1 \leq i \leq m, 1 \leq j \leq n} := S$. Let $I = I(\mathfrak{X})$ be the ideal of X , hence $\mathbb{C}[\mathfrak{X}] \cong S/I(\mathfrak{X})$. Associated to any term order $<$ on the monomial S is a set of standard monomials $\text{Std}_{<}(S/I(\mathfrak{X}))$ (taken with coefficient 1) of S . These monomials form a vector space basis of $S/I(\mathfrak{X})$ over \mathbb{C} ; see Theorem 2.12. We identify each $\mathfrak{m} \in \text{Std}_{<}(S/I(\mathfrak{X}))$ with its exponent vector, represented as a matrix in $\text{Mat}_{m,n}(\mathbb{Z}_{\geq 0})$. Thus under RSK, \mathfrak{m} corresponds to a pair of SSYT $(P|Q)$ of the same shape λ . Kashiwara’s raising and lowering operators e_i, f_i on SSYT define a connected crystal graph structure on the SSYT of shape λ ; see Theorem 4.15. Danilov–Koshevoi [5] and van Leeuwen [30] explain how Kashiwara’s operators “pull-back” to four *bicrystal operators* $e_i^{\text{row}}, e_j^{\text{col}}, f_i^{\text{row}}, f_j^{\text{col}}$ on $\text{Mat}_{m,n}(\mathbb{Z}_{\geq 0})$; see Definition 4.24.

Definition 1.8. $\mathfrak{X} \subseteq \text{Mat}_{m,n}$ is $\mathbf{L}_{\mathbf{I}|\mathbf{J}}$ -bicrystal closed if there exists a term order $<$ such that $e_i^{\text{row}}(\mathfrak{m}), f_i^{\text{row}}(\mathfrak{m}) \in \text{Std}_{<}(S/I(\mathfrak{X})) \cup \{\emptyset\}$ for $\mathfrak{m} \in \text{Std}_{<}(S/I(\mathfrak{X})), i \notin \mathbf{I}$, and $e_j^{\text{col}}(\mathfrak{m}), f_j^{\text{col}}(\mathfrak{m}) \in \text{Std}_{<}(S/I(\mathfrak{X})) \cup \{\emptyset\}$ for $\mathfrak{m} \in \text{Std}_{<}(S/I(\mathfrak{X})), j \notin \mathbf{J}$.

Definition 1.9. $\mathfrak{X} \subseteq \text{Mat}_{m,n}$ is $\mathbf{L}_{\mathbf{I}|\mathbf{J}}$ -bicrystalline if it is $\mathbf{L}_{\mathbf{I}|\mathbf{J}}$ -stable and bicrystal closed.

If $\mathfrak{X} \subseteq \text{Mat}_{m,n}$ is $\mathbf{L}_{\mathbf{I}|\mathbf{J}}$ -stable, $\mathbb{C}[\mathfrak{X}]$ is a $\mathbf{L}_{\mathbf{I}|\mathbf{J}}$ -module by (5). Levi groups being reductive, their representations are completely reducible, that is, their representations are a direct sum of irreducibles. The irreducible representations of $\mathbf{L}_{\mathbf{I}|\mathbf{J}}$ are indexed by tuples of partitions $(\underline{\lambda}|\underline{\mu})$. Their characters are products of *split-Schur polynomials* $s_{\underline{\lambda}}(\mathbf{x}) s_{\underline{\mu}}(\mathbf{y})$, where

$$s_{\underline{\lambda}}(\mathbf{x}) := s_{\lambda(1)}(x_1, \dots, x_{i_1}) s_{\lambda(2)}(x_{i_1+1}, \dots, x_{i_2}) \cdots s_{\lambda(r)}(x_{i_{r-1}+1}, \dots, x_m).$$

There is a formula for the \mathbf{T} -character of $\mathbb{C}[\mathfrak{X}]$, denoted $\chi_{\mathbb{C}[\mathfrak{X}]}$, using the basis of standard monomials. If $\mathfrak{m} = \prod_{1 \leq i \leq m, 1 \leq j \leq n} z_{ij}^{a_{ij}} \in \text{Std}_{<}(S/I(\mathfrak{X}))$ let

$$(7) \quad \text{wt}(\mathfrak{m}) = \prod_{1 \leq i \leq m, 1 \leq j \leq n} (x_i y_j)^{a_{ij}}.$$

The righthand side of (8) is the $\mathbb{Z}^m \times \mathbb{Z}^n$ -multigraded Hilbert series of $\mathbb{C}[\mathfrak{X}]$. Equality follows from the general fact identifying Hilbert series with torus characters; see Section 2:

$$(8) \quad \chi_{\mathbb{C}[\mathfrak{X}]} = \sum_{\mathfrak{m} \in \text{Std}_{<}(S/I(\mathfrak{X}))} \text{wt}(\mathfrak{m}).$$

Definition 1.10. The *highest-weight tableau* of shape λ with entries from $[a, b]$ is the tableau $T_{\lambda, [a, b]}$ of shape λ taking the constant value $a-1+i$ on each row i . The *highest-weight tableau-tuple* $(T_{\underline{\lambda}}|T_{\underline{\mu}})$ of shape $(\underline{\lambda}|\underline{\mu})$ has components $T_{\underline{\lambda}}^{(k)} := T_{\lambda^{(k)}, [i_{k-1}+1, i_k]}$ and $T_{\underline{\mu}}^{(k)} := T_{\mu^{(k)}, [j_{k-1}+1, j_k]}$.

Main Theorem 1.11 (Generalized Cauchy identity). *If $\mathfrak{X} \subseteq \text{Mat}_{m, n}$ is $\mathbf{L}_{\mathbf{I}|\mathbf{J}}$ -bicrystalline, as witnessed by the term order $<$, let $c_{\underline{\lambda}|\underline{\mu}}^{\mathfrak{X}} = \#\{m \in \text{Std}_{<}(S/I(\mathfrak{X})) : \text{filterRSK}_{\mathbf{I}|\mathbf{J}}(m) = (T_{\underline{\lambda}}|T_{\underline{\mu}})\}$. Then*

$$(9) \quad \chi_{\mathbb{C}[\mathfrak{X}]} = \sum_{\underline{\lambda}, \underline{\mu}} c_{\underline{\lambda}|\underline{\mu}}^{\mathfrak{X}} s_{\underline{\lambda}}(\mathbf{x}) s_{\underline{\mu}}(\mathbf{y}).$$

Example 1.12. For any $\mathbf{I}|\mathbf{J}$, $\mathfrak{X} = \text{Mat}_{m, n}$ is $\mathbf{L}_{\mathbf{I}|\mathbf{J}}$ -stable, and, trivially, $\mathbf{L}_{\mathbf{I}|\mathbf{J}}$ -bicrystalline. Letting $c_{\underline{\lambda}|\underline{\mu}} := c_{\underline{\lambda}|\underline{\mu}}^{\text{Mat}_{m, n}}$, we have

$$(10) \quad \prod_{\substack{1 \leq i \leq m \\ 1 \leq j \leq n}} \frac{1}{1 - x_i y_j} = \sum_{\underline{\lambda}, \underline{\mu}} c_{\underline{\lambda}|\underline{\mu}} s_{\underline{\lambda}}(\mathbf{x}) s_{\underline{\mu}}(\mathbf{y}).$$

Remark 1.13 ((10) and Littlewood-Richardson coefficients). Let $\mathbf{I} = \{0 < t < m\}$ and $\mathbf{J} = \{0, n\}$. In this case, (10) becomes

$$\prod_{\substack{1 \leq i \leq m \\ 1 \leq j \leq n}} \frac{1}{1 - x_i y_j} = \sum_{\alpha, \beta} c_{\alpha, \beta}^{\lambda} s_{\alpha}(x_1, \dots, x_t) s_{\beta}(x_{t+1}, x_{t+2}, \dots, x_m) s_{\lambda}(y_1, \dots, y_n),$$

where $c_{\alpha, \beta}^{\lambda}$ is the *Littlewood-Richardson coefficient* (in its coproduct role in the Hopf algebra of symmetric functions); see Example 7.4. So, Theorem 1.11 is a generalized Littlewood-Richardson rule. We speculate that many properties of Littlewood-Richardson coefficients hold, in “good” cases, for $c_{\underline{\lambda}|\underline{\mu}}^{\mathfrak{X}}$. These include *saturation*, *semigroup*, and *SNP* properties, by analogy with work of Knutson–Tao [20], Zelevinsky [32], and of Monical, Tokcan with the third author [24], respectively. Further discussion may appear elsewhere.

1.4. Application to determinantal varieties. Let $B_k \subseteq GL_k$ denote the Borel group of lower triangular matrices, and let $\mathbf{B} = B_m \times B_n \leq \mathbf{GL}$. The \mathbf{B} -stable varieties $\mathfrak{X} \subseteq \text{Mat}_{m, n}$ are known; they are finite unions of the \mathbf{B} -orbit closures of partial permutation matrices. These \mathbf{B} -orbit closures are called *matrix Schubert varieties* and have been extensively studied since their introduction by Fulton in [8]. Knutson–Miller ([17], [18]) and Knutson [16] (see also [19]) describe their standard monomials with respect to appropriate term orders.

We characterize the groups $\mathbf{L}_{\mathbf{I}|\mathbf{J}}$ acting on a given \mathbf{B} -stable variety $\mathfrak{X} \subseteq \text{Mat}_{m, n}$ and show they are bicrystalline, so filterRSK computes their $\mathbf{L}_{\mathbf{I}|\mathbf{J}}$ -characters by Theorem 1.11. The theorem statement below, our second main result, uses notation for partial permutations and their descents from Section 6.1.

Main Theorem 1.14. *Let \mathfrak{X} be a union of the matrix Schubert varieties defined by partial permutations $w_{(1)}, w_{(2)}, \dots, w_{(k)}$. Then \mathfrak{X} is $\mathbf{L}_{\mathbf{I}|\mathbf{J}}$ -stable if the descent positions satisfy $\text{Desc}_{\text{row}}(w_{(i)}) \subseteq \mathbf{I}$ and $\text{Desc}_{\text{col}}(w_{(i)}) \subseteq \mathbf{J}$ for $1 \leq i \leq k$. Moreover \mathfrak{X} is $\mathbf{L}_{\mathbf{I}|\mathbf{J}}$ -bicrystalline.*

Theorem 1.14 generalizes the study of \mathbf{GL} -stable varieties $\mathfrak{X} \subset \text{Mat}_{m, n}$, which are exactly the *classical determinantal varieties* \mathfrak{X}_k of rank $\leq k$ matrices. The \mathbf{T} -characters of these varieties have been long studied (see, e.g., [1, 6, 7, 10, 11, 13]). See Example 7.7.

Example 1.15. Let \mathfrak{X} be the space of 4×4 matrices M such that its northwest 1×1 matrix has rank 0 and its northwest 4×4 submatrix has rank ≤ 3 . In the notation of Section 6.1, this is the matrix Schubert variety \mathfrak{X}_w where w is the partial permutation 213∞ . Now, \mathfrak{X}_w is stable under the action of the Levi group $\mathbf{L}_{\mathbf{I},\mathbf{J}}$ with $\mathbf{I} = \{0, 1, 3, 4\} = \mathbf{J}$: applying row operations on the first row (respectively, column), the second and third rows (respectively, columns), and on the fourth and fifth rows (respectively, columns) of a matrix $M \in \mathfrak{X}$ return matrices in \mathfrak{X} . Here

$$I(\mathfrak{X}) = \left\langle z_{11}, \begin{vmatrix} z_{11} & z_{12} & z_{13} & z_{14} \\ z_{21} & z_{22} & z_{23} & z_{24} \\ z_{31} & z_{32} & z_{33} & z_{34} \\ z_{41} & z_{42} & z_{43} & z_{44} \end{vmatrix} \right\rangle;$$

this is an instance of a theorem of Fulton [8], recapitulated as Theorem 6.8. Let $<$ be the pure lexicographic order obtained by setting $z_{ab} > z_{cd}$ if $a < c$, or $a = c$ and $b > d$. Under this term order, the generators of I form a Gröbner basis; this is a case of the Knutson–Miller Gröbner basis theorem from [17] which is restated here as Theorem 6.10.

Consequently, both

$$A = \begin{bmatrix} 0 & 0 & 1 & 0 \\ 0 & 2 & 0 & 0 \\ 1 & 0 & 0 & 0 \\ 0 & 0 & 0 & 0 \end{bmatrix} \quad \text{and} \quad B = \begin{bmatrix} 0 & 1 & 0 & 0 \\ 1 & 0 & 1 & 0 \\ 0 & 1 & 0 & 0 \\ 0 & 0 & 0 & 0 \end{bmatrix}$$

correspond to standard monomials of $\mathbb{C}[\mathfrak{X}_w]$. Since $\text{row}(A) = \text{col}(A) = 3221$ and $\text{row}(B) = \text{col}(B) = 2132$, applying $\text{filterRSK}_{\mathbf{I},\mathbf{J}}$ to either matrix yields

$$T_{\lambda|\mu} = \left(\begin{array}{c|c} \boxed{1} & \boxed{\begin{array}{cc} 2 & 2 \\ 3 & 3 \end{array}} \\ \hline \boxed{1} & \boxed{\begin{array}{cc} 2 & 2 \\ 3 & 3 \end{array}} \end{array} \right).$$

A and B are the only two such matrices, so $c_{\lambda|\mu}^{\mathfrak{X}_w} = 2$. Additionally, $\chi_{\mathbb{C}[\mathfrak{X}_{213\infty}]}$ starts as:

$$\begin{aligned} & s_{(\emptyset,\emptyset)}(\mathbf{x})s_{(\emptyset,\emptyset)}(\mathbf{y}) + s_{(\emptyset,\square)}(\mathbf{x})s_{(\emptyset,\square)}(\mathbf{y}) + s_{(\square,\emptyset)}(\mathbf{x})s_{(\emptyset,\square)}(\mathbf{y}) + s_{(\emptyset,\square)}(\mathbf{x})s_{(\square,\emptyset)}(\mathbf{y}) + s_{(\emptyset,\boxplus)}(\mathbf{x})s_{(\emptyset,\boxplus)}(\mathbf{y}) + \\ & s_{(\square,\emptyset)}(\mathbf{x})s_{(\emptyset,\boxplus)}(\mathbf{y}) + s_{(\emptyset,\boxplus)}(\mathbf{x})s_{(\emptyset,\boxplus)}(\mathbf{y}) + s_{(\square,\square)}(\mathbf{x})s_{(\emptyset,\boxplus)}(\mathbf{y}) + s_{(\boxplus,\emptyset)}(\mathbf{x})s_{(\emptyset,\boxplus)}(\mathbf{y}) + s_{(\emptyset,\boxplus)}(\mathbf{x})s_{(\square,\emptyset)}(\mathbf{y}) + \\ & s_{(\emptyset,\boxplus)}(\mathbf{x})s_{(\square,\emptyset)}(\mathbf{y}) + s_{(\square,\emptyset)}(\mathbf{x})s_{(\square,\emptyset)}(\mathbf{y}) + s_{(\emptyset,\boxplus)}(\mathbf{x})s_{(\boxplus,\emptyset)}(\mathbf{y}) + s_{(\emptyset,\boxplus)}(\mathbf{x})s_{(\emptyset,\boxplus)}(\mathbf{y}) + s_{(\square,\boxplus)}(\mathbf{x})s_{(\emptyset,\boxplus)}(\mathbf{y}) + \\ & s_{(\emptyset,\boxplus)}(\mathbf{x})s_{(\emptyset,\boxplus)}(\mathbf{y}) + s_{(\square,\boxplus)}(\mathbf{x})s_{(\emptyset,\boxplus)}(\mathbf{y}) + s_{(\boxplus,\emptyset)}(\mathbf{x})s_{(\emptyset,\boxplus)}(\mathbf{y}) + s_{(\boxplus,\emptyset)}(\mathbf{x})s_{(\square,\emptyset)}(\mathbf{y}) + \\ & s_{(\emptyset,\boxplus)}(\mathbf{x})s_{(\square,\emptyset)}(\mathbf{y}) + s_{(\square,\emptyset)}(\mathbf{x})s_{(\square,\emptyset)}(\mathbf{y}) + s_{(\emptyset,\boxplus)}(\mathbf{x})s_{(\boxplus,\emptyset)}(\mathbf{y}) + s_{(\square,\emptyset)}(\mathbf{x})s_{(\square,\emptyset)}(\mathbf{y}) + \\ & s_{(\emptyset,\boxplus)}(\mathbf{x})s_{(\boxplus,\emptyset)}(\mathbf{y}) + s_{(\square,\emptyset)}(\mathbf{x})s_{(\square,\emptyset)}(\mathbf{y}) + s_{(\emptyset,\boxplus)}(\mathbf{x})s_{(\boxplus,\emptyset)}(\mathbf{y}) + s_{(\emptyset,\boxplus)}(\mathbf{x})s_{(\emptyset,\boxplus)}(\mathbf{y}) + \\ & s_{(\square,\emptyset)}(\mathbf{x})s_{(\emptyset,\boxplus)}(\mathbf{y}) + s_{(\boxplus,\emptyset)}(\mathbf{x})s_{(\emptyset,\boxplus)}(\mathbf{y}) + s_{(\boxplus,\emptyset)}(\mathbf{x})s_{(\square,\emptyset)}(\mathbf{y}) + s_{(\square,\emptyset)}(\mathbf{x})s_{(\square,\emptyset)}(\mathbf{y}) + \\ & s_{(\emptyset,\boxplus)}(\mathbf{x})s_{(\emptyset,\boxplus)}(\mathbf{y}) + s_{(\square,\emptyset)}(\mathbf{x})s_{(\emptyset,\boxplus)}(\mathbf{y}) + s_{(\boxplus,\emptyset)}(\mathbf{x})s_{(\emptyset,\boxplus)}(\mathbf{y}) + s_{(\boxplus,\emptyset)}(\mathbf{x})s_{(\emptyset,\boxplus)}(\mathbf{y}) + \\ & s_{(\square,\emptyset)}(\mathbf{x})s_{(\emptyset,\boxplus)}(\mathbf{y}) + s_{(\boxplus,\emptyset)}(\mathbf{x})s_{(\emptyset,\boxplus)}(\mathbf{y}) + s_{(\boxplus,\emptyset)}(\mathbf{x})s_{(\square,\emptyset)}(\mathbf{y}) + s_{(\square,\emptyset)}(\mathbf{x})s_{(\square,\emptyset)}(\mathbf{y}) + \\ & s_{(\emptyset,\boxplus)}(\mathbf{x})s_{(\emptyset,\boxplus)}(\mathbf{y}) + s_{(\square,\emptyset)}(\mathbf{x})s_{(\emptyset,\boxplus)}(\mathbf{y}) + s_{(\boxplus,\emptyset)}(\mathbf{x})s_{(\emptyset,\boxplus)}(\mathbf{y}) + s_{(\boxplus,\emptyset)}(\mathbf{x})s_{(\emptyset,\boxplus)}(\mathbf{y}) + \\ & s_{(\square,\emptyset)}(\mathbf{x})s_{(\emptyset,\boxplus)}(\mathbf{y}) + s_{(\boxplus,\emptyset)}(\mathbf{x})s_{(\emptyset,\boxplus)}(\mathbf{y}) + s_{(\boxplus,\emptyset)}(\mathbf{x})s_{(\square,\emptyset)}(\mathbf{y}) + s_{(\square,\emptyset)}(\mathbf{x})s_{(\square,\emptyset)}(\mathbf{y}) + \\ & s_{(\emptyset,\boxplus)}(\mathbf{x})s_{(\emptyset,\boxplus)}(\mathbf{y}) + s_{(\square,\emptyset)}(\mathbf{x})s_{(\emptyset,\boxplus)}(\mathbf{y}) + s_{(\boxplus,\emptyset)}(\mathbf{x})s_{(\emptyset,\boxplus)}(\mathbf{y}) + s_{(\boxplus,\emptyset)}(\mathbf{x})s_{(\emptyset,\boxplus)}(\mathbf{y}) + \dots \end{aligned}$$

1.5. **Organization.** Section 2 presents algebraic preliminaries. We begin with general notions about (reductive) linear algebraic groups, their representations and characters, and the irreducible decomposition problem in the representation ring. Then we discuss Gröbner basis notions, specifically *standard monomials* and computation of \mathbf{T} -characters. Finally, we specialize to the setting of this paper, explaining, e.g., why the characters of irreducible representations of $L_{\mathbf{I}|\mathbf{J}}$ are the split-Schur polynomials $s_{\underline{\lambda}}(\mathbf{x})s_{\underline{\mu}}(\mathbf{y})$.

Section 3 covers the tableau notions we need: semistandard Young tableaux and their reading words, Knuth equivalence, row insertion, and filterRSK in terms of insertion.

Section 4 discusses Kashiwara’s *crystal graphs*. Section 4.1 reviews *crystal graphs* on words and tableaux, stating and proving some preparatory results. Section 4.2 concerns the *bicrystal* structure on matrices found by Danilov–Koshevoi [5] and van Leeuwen [30]. We phrase results in terms of local isomorphisms of pre-crystal graphs.

Section 5 introduces filterings, which combined with the build-up from Sections 3 and 4, culminates in Theorem 5.9, the “bicrystal categorification” of Theorem 1.11. It generalizes results of [5, 30]. With this theorem, the Main Theorem 1.11 follows, in view of the ideas laid out in Section 2.

Section 6 concerns the main case of \mathbf{B} -stable varieties. We define matrix Schubert varieties \mathfrak{X}_w and state basic results drawn from Fulton’s [8]. We then recall the description of the standard monomials of $\mathbb{C}[\mathfrak{X}_w]$ from Knutson–Miller’s [17] and the extension to arbitrary \mathbf{B} -stable varieties from Knutson’s [16]. This allows us to prove Theorem 1.14, showing that the $L_{\mathbf{I}|\mathbf{J}}$ -characters of \mathbf{B} -stable varieties are computed by filterRSK.

Section 7 offers final remarks. Proposition 7.1 shows that $c_{\underline{\lambda}|\underline{\mu}}$ counts lattice points in a polytope. It allows one to reprove the classical Cauchy identity and formulate a polytopal Littlewood–Richardson rule. Proposition 7.5 and Remark 7.6 give an extension for any $c_{\underline{\lambda}|\underline{\mu}}^{\mathfrak{X}}$. We then rederive the Cauchy-type identity for classical determinantal varieties.

2. BACKGROUND ON REPRESENTATION THEORY AND COMMUTATIVE ALGEBRA

2.1. **Reductive groups, maximal tori, and characters.** We assume throughout that all groups G have the structure of an affine variety over the base field \mathbb{C} of complex numbers. These are the (*complex*) *linear algebraic groups*, so called because they are isomorphic to closed subgroups of GL_n [23, Corollary 4.10]. Our primary reference is [23].

Let V be a \mathbb{C} -algebra. By a (*rational*) *representation* of G we mean a homomorphism

$$\rho : G \rightarrow GL(V)$$

that is also a morphism of varieties, where $GL(V)$ is the (linear algebraic) group of invertible linear transformations of V . V is a $\mathbb{C}[G]$ -module via the action $g \cdot v = \rho(g)v$.

A representation V of G is *irreducible* if it contains no nontrivial G -invariant subspaces. Irreducible representations of G are finite-dimensional [23, Corollary 4.8]. We call G over \mathbb{C} *reductive* if any representation of G is a direct sum of irreducible representations.

Example 2.1. Our main examples of linear algebraic groups are the matrix groups \mathbf{GL} , $L_{\mathbf{I}|\mathbf{J}}$, and \mathbf{T} from the introduction. Additionally, any finite group G may be viewed as a linear algebraic group by first using Cayley’s theorem to embed G in a symmetric group \mathfrak{S}_n and then embedding \mathfrak{S}_n in GL_n as permutation matrices. All of these groups are reductive.

When G is a reductive group, the *representation ring* $\text{Rep}(G)$ consists of formal \mathbb{Z} -linear combinations of isomorphism classes of finite-dimensional representations, with direct sums and tensor products of representations as the ring operations. As a \mathbb{Z} -module, it has a basis given by classes of irreducible representations of G . Given a representation V of a reductive group G , one asks *how to express the class of V in $\text{Rep}(G)$ in terms of this basis?* Let us call this the “decomposition problem”.

In the case where $G = T$ is an (*algebraic*) *torus* (i.e., $T \cong (\mathbb{C}^*)^k$ for some k), the irreducible representations are particularly easy to describe.

Theorem 2.2 ([23, Theorem 12.12]). *The irreducible representations of $T \cong (\mathbb{C}^*)^k$ are one-dimensional, indexed by integer k -tuples $\mathbf{a} = (a_1, \dots, a_k) \in \mathbb{Z}^k$. The action of $\mathbf{t} = (t_1, \dots, t_k) \in T$ on the irreducible representation $V_{\mathbf{a}}$ is given by $\mathbf{t} \cdot v = t_1^{a_1} \dots t_k^{a_k} v$.*

Definition 2.3. Let $T \cong (\mathbb{C}^*)^k$ be a torus. Let $V = \bigoplus_{\mathbf{a}} c_{\mathbf{a}} V_{\mathbf{a}}$ be a T -representation. The *character* of V is

$$\chi_V = \sum_{\mathbf{a}} c_{\mathbf{a}} \mathbf{t}^{\mathbf{a}} \in \mathbb{Z}[[\mathbf{t}^{\pm 1}]] = \mathbb{Z}[[t_1^{\pm 1}, \dots, t_k^{\pm 1}]].$$

Assume for the moment that V is a finite-dimensional T -representation via the action $\rho : T \rightarrow GL(V)$, so $\chi_V \in \mathbb{Z}[\mathbf{t}^{\pm 1}]$ is a Laurent polynomial. The T -action on V defines a *multigrading* on V : an element $v \in V$ is *T -homogeneous of multidegree \mathbf{a}* if $\text{span}(v)$ is isomorphic to $V_{\mathbf{a}}$ as a T -representation. The *weight* of v is then the monomial $\text{wt}_T(v) = \mathbf{t}^{\mathbf{a}} \in \mathbb{Z}[\mathbf{t}^{\pm 1}]$. In later sections we will work with the equivalent *combinatorial weight* of v , which is the k -tuple $\text{cwt}_T(v) = \mathbf{a} \in \mathbb{Z}^k$. By Theorem 2.2 and the fact that T is reductive, V must have a *T -homogeneous basis* \mathfrak{B} (meaning each $v \in \mathfrak{B}$ is T -homogeneous). Then the elements of \mathfrak{B} form a full basis of eigenvectors for every matrix $\rho(\mathbf{t})$ ($\mathbf{t} \in T$) and the eigenvalues of $\rho(\mathbf{t})$ are the weights $\mathbf{t}^{\mathbf{a}}$. The character χ_V is thus concretely realized as the function mapping \mathbf{t} to the sum of the eigenvalues of $\rho(\mathbf{t})$. That is, we have the formula

$$(11) \quad \chi_V = \text{Trace}(\rho(\mathbf{t})) \in \mathbb{Z}[\mathbf{t}^{\pm 1}].$$

Theorem 2.2 helps to understand the decomposition problem for other connected reductive groups G since any such group contains a nontrivial algebraic torus ([23, Theorem 16.60]). A *split reductive group* is a pair (G, T) of a connected reductive group G and a maximal torus T in G . The maximal tori in G are all conjugate to one another, so the particular choice of T matters little ([23, Theorem 17.10, 21.43]).

When (G, T) is split reductive, any G -representation is also a T -representation, and taking characters then defines a ring homomorphism

$$(12) \quad \text{ch} : \text{Rep}(G) \rightarrow \mathbb{Z}[\mathbf{t}^{\pm 1}].$$

If $G = T$, ch is an isomorphism: $\text{Rep}(T) \cong \mathbb{Z}[\mathbf{t}^{\pm 1}]$. In general, the image of ch is determined by the *Weyl group* W of G , which is $N_G(T)/T$ where $N_G(T)$ is the normalizer of T in G .

Theorem 2.4 ([23, Theorem 22.38]). *If (G, T) is a split reductive group, then the character map ch of (12) is an isomorphism onto the subring $\mathbb{Z}[\mathbf{t}^{\pm 1}]^W$ of W -invariant T -characters. In particular, the characters of irreducible G -representations V_{λ} form a \mathbb{Z} -module basis for $\mathbb{Z}[\mathbf{t}^{\pm 1}]^W \cong \text{Rep}(G)$.*

Definition 2.5. Let (G, T) be a split reductive group with Weyl group W . The *character* of a G -representation V is defined to be its character $\chi_V \in \mathbb{Z}[\mathbf{t}^{\pm 1}]$ as a T -representation.

In principle, Theorem 2.4 solves the decomposition problem for G , albeit in a manner that does not combinatorially exhibit the positivity of the coefficients. Given a representation V of G , first compute its character $\chi_V \in \mathbb{Z}[\mathfrak{t}^{\pm 1}]$. By Theorem 2.4, χ_V in fact lies in $\mathbb{Z}[\mathfrak{t}^{\pm 1}]^W \cong \text{Rep}(G)$ and there is a unique expression $\chi_V = \sum_{\lambda} c_{\lambda} \chi_{V_{\lambda}}$ (where the sum is over irreducible representations of G). Hence,

$$[V] = \sum_{\lambda} c_{\lambda} [V_{\lambda}] \in \text{Rep}(G),$$

or equivalently, $V \cong_G \bigoplus_{\lambda} V_{\lambda}^{\oplus c_{\lambda}}$. Determination of $\chi_V \in \mathbb{Z}[\mathfrak{t}^{\pm 1}]$ may be difficult in general. However, standard combinatorial commutative algebra will provide the method in the context of this paper, as summarized in Proposition 2.17.

We need the irreducible representations for a product of split reductive groups in terms of the irreducible representations of the factors.

Definition 2.6. Let V and V' be representations of linear algebraic groups G and G' . The (exterior) tensor product representation $V \boxtimes V'$ of $G \times G'$ is the tensor product of V and V' as vector spaces with the action $(g, g') \cdot (v \otimes v') = (g \cdot v) \otimes (g' \cdot v')$.

The following type of statement is standard. See [28, Lemma 68] for a more general statement than the second sentence (it assumes an algebraically closed field, which is our case). The compact Lie group case is textbook, and sufficient for our application, since for general linear groups one reduces to compact case of U_n by Weyl's unitarian trick.

Proposition 2.7. *If (G, T) and (G', T') are split reductive groups, then $(G \times G', T \times T')$ is also split reductive. The irreducible representations of $G \times G'$ are exactly tensor products $V_{\lambda} \boxtimes V_{\mu}$ of irreducible representations of the factors.*

In our application, $V = \bigoplus_{i \geq 0} V_i$ is a graded, infinite-dimensional vector space where each graded component V_i is a finite-dimensional representation of G . Hence, our analysis occurs in the completion $\widehat{\text{Rep}}(G)$ of $\text{Rep}(G)$. This allows for infinite linear combinations of isomorphism classes of representations. This causes no difficulty as computing this class in $\widehat{\text{Rep}}(G)$ may be interpreted as solving a $\mathbb{Z}_{\geq 0}$ -indexed set of finite-dimensional decomposition problems, one for each V_i . (In the case $G = T$, $\widehat{\text{Rep}}(G) \cong \mathbb{Z}[[t_1^{\pm 1}, \dots, t_k^{\pm 1}]]$.)

2.2. Representations from affine varieties. Our G -modules of interest come as coordinate rings of algebraic varieties. We now review the basics.

Definition 2.8. Let G be a linear algebraic group. A G -variety \mathfrak{X} is a variety equipped with a rational action of G .

Example 2.9. The space $\text{Mat}_{m,n}$ is a GL -variety under the usual multiplication action. By restriction $\text{Mat}_{m,n}$ is also a $\text{L}_{\text{I|J}}$ -variety and a T -variety. Any linear algebraic group G , being an affine variety, is also a G -variety under the multiplication or conjugation actions.

While a G -variety \mathfrak{X} is usually not a representation of G because it has no vector space structure, the coordinate ring $\mathbb{C}[\mathfrak{X}]$ is a G -representation via the action

$$(13) \quad g \cdot f(\mathbf{x}) := f(g^{-1} \cdot \mathbf{x}), \quad \text{for } g \in G, \mathbf{x} \in \mathfrak{X}, f \in \mathbb{C}[\mathfrak{X}].$$

If G is reductive and \mathfrak{X} is a G -variety, then $\mathbb{C}[\mathfrak{X}]$ decomposes into a direct sum of irreducible G -representations. When (G, T) is a split reductive group, the T -action on $\mathbb{C}[\mathfrak{X}]$

defines a multigrading, and the G -character (i.e., the T -character) is exactly the multigraded Hilbert series of \mathfrak{X} in the sense of [22]. Section 2.1 suggests how to compute the decomposition of $\mathbb{C}[\mathfrak{X}]$ into G -irreducibles. To proceed, we introduce coordinates on \mathfrak{X} in order to give an explicit T -homogenous basis on $\mathbb{C}[\mathfrak{X}]$ and compute the T -character $\chi_{\mathbb{C}[\mathfrak{X}]}$.

Let \mathfrak{X} be an affine variety, realized in coordinates as a closed subset of \mathbb{C}^N for some N . Then the coordinate ring $\mathbb{C}[\mathfrak{X}]$ is realized as the quotient ring $S/I(\mathfrak{X})$, where $S := \mathbb{C}[z_1, \dots, z_N]$ and $I(\mathfrak{X})$ is the defining ideal of \mathfrak{X} . As a vector space, S has an infinite basis given by all monomials in the variables z_1, \dots, z_N . The images of these monomials under the quotient map $q : S \rightarrow S/I(\mathfrak{X})$ then generate $\mathbb{C}[\mathfrak{X}]$ as a vector space, but they are generally not a basis: the relations in the quotient impose linear dependencies between some of the monomials. *Gröbner bases* allow one to cut down this generating set to a vector space basis for $S/I(\mathfrak{X})$; we recall the basic definitions with [4] as our reference.

Definition 2.10. Let $I \subseteq S = \mathbb{C}[z_1, \dots, z_N]$ be an ideal, and let $<$ be a *term order*. The *initial ideal* of I with respect to $<$ is the monomial ideal $\text{init}_{<}(I) := \langle \text{LT}_{<}(f) \mid f \in I \rangle$, where $\text{LT}_{<}(f)$ denotes the lead term of f under the term order $<$.

Definition 2.11. Let $I \subseteq S$ be an ideal and $<$ a term order as above. The set of *standard monomials* for S/I with respect to $<$ is the set $\text{Std}_{<}(S/I)$ of all monomials not in $\text{init}_{<}(I)$, taken with coefficient 1.

Theorem 2.12 ([4, Section 2.2]). *Fix a term order $<$. $\text{Std}_{<}(S/I)$ is a vector space basis for S/I .*

Definition 2.13. A *Gröbner basis* for $I \subseteq S$ is a finite set $\{f_i\}_{i=1}^k \subseteq I$ such that $\text{init}_{<}(I) = \langle \text{LT}(f_i) \mid 1 \leq i \leq k \rangle$.

Theorem 2.14 (Buchberger's Algorithm, [4, Section 1.3]). *Any generating set of an ideal $I \subseteq S$ can be extended to a Gröbner basis via a finite algorithm.*

Thus, a vector space basis for S/I is obtained by taking generators for I , extending them to a Gröbner basis with respect to some term order $<$, and describing $\text{Std}_{<}(S/I)$ as those monomials not divisible by the lead term of any element of the Gröbner basis.

Definition 2.15. The *natural torus* on \mathbb{C}^N is $T = (\mathbb{C}^*)^N$, with the action $(\mathbb{C}^*)^N \times \mathbb{C}^N \rightarrow \mathbb{C}^N$ given by scaling each component. The *fine multigrading* on $S = \mathbb{C}[z_1, \dots, z_N]$ is the multigrading induced by the natural torus action.

The monomials of $\mathbb{C}[z_1, \dots, z_N]$ are all homogeneous with respect to the natural torus action of $(\mathbb{C}^*)^N$ on \mathbb{C}^N . The next definition gives sufficient conditions for the standard monomials of a T -variety \mathfrak{X} to be T -homogeneous.

Definition 2.16. Let $T \cong (\mathbb{C}^*)^k$ be a torus and let \mathfrak{X} be a T -variety. An embedding $\iota : \mathfrak{X} \rightarrow \mathbb{C}^N$ is *T -compatible* if there is an algebraic group homomorphism $\iota' : T \rightarrow (\mathbb{C}^*)^N$ such that the T -action on \mathfrak{X} is given by the natural torus action on \mathbb{C}^N , restricted to the image of ι' .

In summary, for split reductive groups (G, T) we have the following method for decomposing representations arising from affine G -varieties:

Proposition 2.17. *Let (G, T) be a split reductive group. Let \mathfrak{X} be a G -variety with a T -compatible embedding such that $\mathbb{C}[\mathfrak{X}] \cong S/I(\mathfrak{X})$. Express the sum of the T -weights of the elements of $\text{Std}_{<}(S/I(\mathfrak{X}))$ as a linear combination $\sum_{\lambda} c_{\lambda} \chi_{V_{\lambda}}$ of irreducible G -characters. Then*

$$\mathbb{C}[\mathfrak{X}] \cong \bigoplus_{\lambda} V_{\lambda}^{\oplus c_{\lambda}}.$$

Proof. Theorem 2.12 states that $\text{Std}_<(S/I(\mathfrak{X}))$ forms a basis for $S/I(\mathfrak{X}) \cong \mathbb{C}[\mathfrak{X}]$. The T -compatible hypothesis says that each of these basis elements is T -homogeneous. Thus we obtain the T -weight space decomposition of $\mathbb{C}[\mathfrak{X}] \cong S/I(\mathfrak{X})$ as guaranteed by Theorem 2.2. The expression indicated in the second sentence of the statement is then the T -character of $\mathbb{C}[\mathfrak{X}] \cong S/I(\mathfrak{X})$ in the sense of Definition 2.5. Now apply Theorem 2.4 (and the discussion immediately after Definition 2.5). \square

2.3. The general linear group and its Levi groups. We now specialize to the setting of this paper. All varieties considered are T -stable subvarieties of $\text{Mat}_{m,n} \cong \mathbb{C}^{mn}$, with T a subtorus of the natural torus $(\mathbb{C}^*)^{mn}$. The groups $L_{I|J}$ used are products of general linear subgroups, so we begin by describing their representation theory more explicitly.

The (complex) general linear group GL_k is reductive, and the group $T_k \subseteq GL_k$ of invertible diagonal matrices is a maximal torus. The associated Weyl group is the symmetric group \mathfrak{S}_k , so by Theorem 2.4 the space of polynomial GL_k -characters is isomorphic to the ring of symmetric polynomials $\Lambda[t_1, \dots, t_k] := \mathbb{Z}[t_1, \dots, t_k]^{\mathfrak{S}_k}$, with a \mathbb{Z} -module basis given by the characters of irreducible GL_k -representations.

Theorem 2.18 ([9, Theorem 8.2.2]). *The irreducible polynomial representations of GL_k are the Weyl modules V_λ indexed by partitions λ with at most k rows. The character of V_λ is the Schur polynomial $s_\lambda(t_1, \dots, t_k)$ previously defined in (2).*

First, suppose that V is a finite-dimensional GL_k -representation, realized through a homomorphism $\rho : GL_k \rightarrow GL(V)$. Since GL_k is reductive, it follows that $V = \bigoplus_\lambda V_\lambda^{c_\lambda}$ for some nonnegative integers c_λ . We concretely compute the coefficients c_λ by expressing the character $\chi_V(\mathbf{t}) = \text{Trace}(\rho(\mathbf{t}))$ as $\sum_\lambda c_\lambda s_\lambda(\mathbf{t})$ in the basis of Schur polynomials.

Example 2.19. Let $V = \text{Sym}^2(\mathbb{C}^2)$ be the \mathbb{C} -vector subspace of $\mathbb{C}[x, y]$ spanned by $\{x^2, 2xy, y^2\}$. $GL_2(\mathbb{C})$ acts on V by $x \mapsto (ax + cy)$, $y \mapsto (bx + dy)$. This induces a change of basis

$$x^2 \mapsto (ax + cy)^2, \quad 2xy \mapsto 2(ax + cy)(bx + dy), \quad y^2 \mapsto (bx + dy)^2.$$

After identifying $V \cong \mathbb{C}^3$, we can express the $\mathbb{C}[GL_2(\mathbb{C})]$ -module V as a linear representation, by sending a generic 2×2 matrix to the change of basis matrix:

$$\rho : GL_2(\mathbb{C}) \rightarrow GL_3(\mathbb{C})$$

$$\begin{bmatrix} a & b \\ c & d \end{bmatrix} \mapsto \begin{bmatrix} a^2 & 2ab & b^2 \\ ac & bc + ad & bd \\ c^2 & 2cd & d^2 \end{bmatrix}.$$

Hence, $\rho\left(\begin{bmatrix} t_1 & 0 \\ 0 & t_2 \end{bmatrix}\right) = \begin{bmatrix} t_1^2 & 0 & 0 \\ 0 & t_1 t_2 & 0 \\ 0 & 0 & t_2^2 \end{bmatrix}$ and, by (11), $\chi_V = t_1^2 + t_1 t_2 + t_2^2 = s_{\square\square}(t_1, t_2)$. Thus V is isomorphic to the Weyl module $V_{\square\square}$.

By Proposition 2.7, the representation theory of GL_k encapsulated in Theorem 2.18 extends immediately to characterize the irreducible representations of products $GL_k \times GL_l$. They are tensor products $V_\lambda \boxtimes V_\mu$ of Weyl modules, with characters given by the corresponding products $s_\lambda(t_1, \dots, t_k) s_\mu(t'_1, \dots, t'_l)$ of Schur polynomials. The following example realizes this construction explicitly using the Kronecker product of matrices.

Example 2.20. Consider the $GL_2 \times GL_2$ action on $\text{Sym}^2(\mathbb{C}^2) \boxtimes \text{Sym}^2(\mathbb{C}^2)$. A basis consists of: $x^2 \otimes x^2, x^2 \otimes (2xy), x^2 \otimes y^2, (2xy) \otimes x^2, (2xy) \otimes (2xy), (2xy) \otimes y^2, y^2 \otimes x^2, y^2 \otimes (2xy), y^2 \otimes y^2$.

Suppose a generic element of $GL_2 \times GL_2$ is $(g, h) = \left(\begin{bmatrix} a & b \\ c & d \end{bmatrix}, \begin{bmatrix} q & r \\ s & t \end{bmatrix} \right)$. Then, the action induces a change of basis, e.g., $x^2 \otimes y^2 \mapsto (ax + cy)^2 \otimes (rx + ty)^2$. The change of basis matrix is

$$\begin{bmatrix} a^2 & 2ab & b^2 \\ ac & bc+ad & bd \\ c^2 & 2cd & d^2 \end{bmatrix} \otimes \begin{bmatrix} q^2 & 2qr & r^2 \\ qs & rs+qt & rt \\ s^2 & 2st & t^2 \end{bmatrix} := \begin{bmatrix} a^2 \begin{bmatrix} q^2 & 2qr & r^2 \\ qs & rs+qt & rt \\ s^2 & 2st & t^2 \end{bmatrix} & 2ab \begin{bmatrix} q^2 & 2qr & r^2 \\ qs & rs+qt & rt \\ s^2 & 2st & t^2 \end{bmatrix} & b^2 \begin{bmatrix} q^2 & 2qr & r^2 \\ qs & rs+qt & rt \\ s^2 & 2st & t^2 \end{bmatrix} \\ ac \begin{bmatrix} q^2 & 2qr & r^2 \\ qs & rs+qt & rt \\ s^2 & 2st & t^2 \end{bmatrix} & (bc+ad) \begin{bmatrix} q^2 & 2qr & r^2 \\ qs & rs+qt & rt \\ s^2 & 2st & t^2 \end{bmatrix} & bd \begin{bmatrix} q^2 & 2qr & r^2 \\ qs & rs+qt & rt \\ s^2 & 2st & t^2 \end{bmatrix} \\ c^2 \begin{bmatrix} q^2 & 2qr & r^2 \\ qs & rs+qt & rt \\ s^2 & 2st & t^2 \end{bmatrix} & 2cd \begin{bmatrix} q^2 & 2qr & r^2 \\ qs & rs+qt & rt \\ s^2 & 2st & t^2 \end{bmatrix} & d^2 \begin{bmatrix} q^2 & 2qr & r^2 \\ qs & rs+qt & rt \\ s^2 & 2st & t^2 \end{bmatrix} \end{bmatrix}.$$

That is, the homomorphism describing this representation is

$$\theta \left(\begin{bmatrix} a & b \\ c & d \end{bmatrix}, \begin{bmatrix} q & r \\ s & t \end{bmatrix} \right) = \begin{bmatrix} a^2 & 2ab & b^2 \\ ac & bc+ad & bd \\ c^2 & 2cd & d^2 \end{bmatrix} \otimes \begin{bmatrix} q^2 & 2qr & r^2 \\ qs & rs+qt & rt \\ s^2 & 2st & t^2 \end{bmatrix}$$

The character of this representation is $\text{Trace} \left(\theta \left(\begin{bmatrix} t_1 & 0 \\ 0 & t_2 \end{bmatrix}, \begin{bmatrix} t'_1 & 0 \\ 0 & t'_2 \end{bmatrix} \right) \right)$, and the reader can check this indeed equals $\chi_\rho(t_1, t_2)\chi_\rho(t'_1, t'_2)$.

The GL_k representations we consider are constructed from the following basic example. Consider \mathbb{C}^k as an affine space. Viewing an element $v \in \mathbb{C}^k$ as a column vector, we realize \mathbb{C}^k as a GL_k -variety via the right action $v \cdot g = g^{-1}v$. If $\mathfrak{X} \subseteq \mathbb{C}^k$ is a subvariety stable under this action, the formula (13) then gives a left GL_k action on the coordinate ring $\mathbb{C}[\mathfrak{X}] \cong S/I(\mathfrak{X})$, where $S = \mathbb{C}[z_1, \dots, z_k]$. The torus $T_k \subseteq GL_k$ of invertible diagonal matrices is precisely the natural torus acting on \mathbb{C}^k from Definition 2.15, so the T_k -weight of each monomial m is obtained by making the substitutions $z_i \mapsto t_i$ for all $1 \leq i \leq k$. By Proposition 2.17, we may compute the decomposition of $\mathbb{C}[\mathfrak{X}]$ into irreducible GL_k -representations by identifying the constants $c_\lambda^{\mathfrak{X}}$ such that

$$(14) \quad \sum_{m \in \text{Std}_{<}(S/I(\mathfrak{X}))} \text{wt}_{T_k}(m) = \sum_{\lambda} c_\lambda^{\mathfrak{X}} s_\lambda(\mathbf{t}).$$

Since $V = \mathbb{C}[\mathfrak{X}]$ is generally infinite-dimensional, the expression (14) technically lives in the completion $\Lambda[\widehat{t_1, \dots, t_k}] \cong \widehat{\text{Rep}(GL_k)}$ of the ring of symmetric polynomials, which allows infinite linear combinations of Schur polynomials (see, e.g., [27, pg. 291]). This causes no concern since $V = \bigoplus_{i \geq 0} V_i$ is a standard graded ring where each V_i is a finite-dimensional GL_k -module. All copies of the Weyl module V_λ in V must lie in the graded component $V_{|\lambda|}$, so all coefficients in (14) are finite.

Letting $\mathbf{I} = \{0 = i_0 < \dots < i_r = k\}$, the subgroup $L_{\mathbf{I}} = GL_{i_1-i_0} \times \dots \times GL_{i_r-i_{r-1}}$ of $k \times k$ invertible block-diagonal matrices also acts on \mathbb{C}^k by restriction. If \mathfrak{X} is stable under this restricted action, then $\mathbb{C}[\mathfrak{X}]$ decomposes into a sum of *split-Weyl modules* $V_{\underline{\lambda}} := V_{\lambda^{(1)}} \boxtimes \dots \boxtimes V_{\lambda^{(r)}}$, where each $\lambda^{(a)}$ is a partition with at most $i_a - i_{a-1}$ rows. The character of $V_{\underline{\lambda}}$ is the split-Schur polynomial $s_{\underline{\lambda}}(\mathbf{t})$ from the introduction (cf. [14, Definition 4.3]). The group T_k is also a maximal torus for $L_{\mathbf{I}}$, so by Proposition 2.17 again we decompose $\mathbb{C}[\mathfrak{X}]$ into irreducible $L_{\mathbf{I}}$ -representations by identifying constants $c_{\underline{\lambda}}^{\mathfrak{X}}$ such that

$$(15) \quad \sum_{m \in \text{Std}_{<}(S/I(\mathfrak{X}))} \text{wt}_{T_k}(m) = \sum_{\underline{\lambda}} c_{\underline{\lambda}}^{\mathfrak{X}} s_{\underline{\lambda}}(\mathbf{t}).$$

As with (14), (15) lives in $\widehat{\text{Rep}(L_{\mathbf{I}})} \cong \Lambda[\widehat{t_1, \dots, t_{i_1}}] \boxtimes \dots \boxtimes \Lambda[\widehat{t_{i_{r-1}+1}, \dots, t_{i_r}}]$.

Now, the GL_m -action on \mathbb{C}^m and GL_n -action on \mathbb{C}^n combine to give the $\mathbf{GL} := GL_m \times GL_n$ -action $(v \otimes w) \cdot (p, q) = (v \cdot p) \otimes (w \cdot q)$ on $\mathbb{C}^m \boxtimes \mathbb{C}^n$. Identifying $\mathbb{C}^m \boxtimes \mathbb{C}^n$ with the matrix space $\text{Mat}_{m,n}$, this is the action (4) seen in the introduction. This action restricts to a $\mathbf{L}_{\mathbf{I}|\mathbf{J}} := L_{\mathbf{I}} \times L_{\mathbf{J}}$ -action for any indexing sets $\mathbf{I} = \{0 = i_0 < \dots < i_r = m\}$ and $\mathbf{J} = \{0 < j_0 < \dots < j_s = n\}$. If $\mathfrak{X} \subseteq \text{Mat}_{m,n}$ is a subvariety stable under this $\mathbf{L}_{\mathbf{I}|\mathbf{J}}$ action, then applying (13) gives us the left $\mathbf{L}_{\mathbf{I}|\mathbf{J}}$ -action (5) on the coordinate ring $\mathbb{C}[\mathfrak{X}] \cong S/I(\mathfrak{X})$, where $S = \mathbb{C}[z_{11}, \dots, z_{mn}]$. The maximal torus $\mathbf{T} = T_m \times T_n$ in $\mathbf{L}_{\mathbf{I}|\mathbf{J}}$ is a subtorus of the natural torus acting on $\text{Mat}_{m,n} \cong \mathbb{C}^{mn}$: the \mathbf{T} -weight of a monomial $\mathbf{m} \in S$ is obtained by making the substitutions $z_{ij} \mapsto x_i y_j$ for each variable. Applying Proposition 2.17 one more time, we see that the decomposition of $\mathbb{C}[\mathfrak{X}]$ into irreducible $\mathbf{L}_{\mathbf{I}|\mathbf{J}}$ -representations is computed by identifying constants $c_{\underline{\lambda}|\underline{\mu}}^{\mathfrak{X}}$ such that

$$\sum_{\mathbf{m} \in \text{Std}_{<}(S/I(\mathfrak{X}))} \text{wt}_{\mathbf{T}}(\mathbf{m}) = \sum_{\underline{\lambda}|\underline{\mu}} c_{\underline{\lambda}|\underline{\mu}}^{\mathfrak{X}} s_{\underline{\lambda}}(\mathbf{x}) s_{\underline{\mu}}(\mathbf{y}) \in \widehat{\text{Rep}}(\mathbf{L}_{\mathbf{I}|\mathbf{J}}),$$

where $\text{wt}_{\mathbf{T}}$ is the same thing as wt from (7) and

$$\widehat{\text{Rep}}(\mathbf{L}_{\mathbf{I}|\mathbf{J}}) \cong \left(\Lambda[\widehat{x_1, \dots, t_{i_1}}] \boxtimes \dots \boxtimes \Lambda[\widehat{x_{i_{r-1}+1}, \dots, x_{i_r}}] \right) \boxtimes \left(\Lambda[\widehat{y_1, \dots, y_{j_1}}] \boxtimes \dots \boxtimes \Lambda[\widehat{y_{j_{s-1}+1}, \dots, y_{j_s}}] \right).$$

3. TABLEAUX

We review some standard notions from tableau combinatorics, with [9] as our primary reference. Let λ be an integer partition, which we identify with its Young diagram.

Definition 3.1. A *semistandard Young tableau* T of shape $\lambda = \text{shape}(T)$ is a filling of the cells of λ with positive integer entries such that the entries increase weakly along rows from left to right, and the entries increase strictly along columns from top to bottom.

Example 3.2. The partition $\lambda = (4, 2, 2)$ has Young diagram

. One semistandard

tableau of shape λ is $T =$

1	1	2	3
3	3		
4	5		

.

Let $\text{SSYT}(\lambda, [a, b])$ be the set of semistandard Young tableaux of shape λ where the entries come from the interval $[a, b]$. Let

$$\text{SSYT}(\lambda) := \text{SSYT}(\lambda, [1, \infty)) \quad \text{and} \quad \text{SSYT} := \bigcup_{\lambda} \text{SSYT}(\lambda).$$

Definition 3.3. The (column) *reading word* of a tableau T , $\text{word}(T)$, reads the entries of each column bottom-to-top, starting from the leftmost column and proceeding rightward.

Example 3.4. If $T =$

1	2	2	3
2	4		
3	5		

 then $\text{word}(T) = 32154223$.

If we know that $w = \text{word}(T)$ for some tableau T , we can reconstruct T from w : the strictly decreasing sequences in w are exactly the columns of T , read from bottom to top. However, many words cannot be realized as $\text{word}(T)$ for any T . We now recall the notion of *Knuth equivalence*, which relates any word to the reading word of a unique tableau.

Definition 3.5. Let $x, y, z \in \mathbb{N}$ be letters. The *elementary Knuth moves* are

$$(16) \quad yzx \leftrightarrow yxz \quad (x < y \leq z)$$

and

$$(17) \quad zxy \leftrightarrow xzy \quad (x \leq y < z).$$

Two words w and w' are *Knuth equivalent*, denoted $w \sim_K w'$, if they are connected by a sequence of elementary Knuth moves.

Theorem 3.6. For every word w , there is a unique $T \in \text{SSYT}$ such that $w \sim_K \text{word}(T)$.

There are various algorithms for constructing the tableau T such that $w \sim_K \text{word}(T)$. We employ the following *row insertion algorithm*.

Definition 3.7. The *row insertion* of x into $T \in \text{SSYT}$ is a tableau denoted $T \leftarrow x$. If no element of the first row of T is strictly greater than x , then x is appended to the end of that row. Otherwise, let y be the first element in the first row of T such that $x < y$. Replace y with x and insert y into the second row of T using the same procedure. This process eventually terminates, producing $T \leftarrow x$.

Example 3.8. Let $T = \begin{array}{|c|c|c|c|} \hline 1 & 2 & 2 & 3 \\ \hline 2 & 5 & & \\ \hline 4 & & & \\ \hline \end{array}$ and let $x = 1$. Inserting 1 into the first row of T bumps out

a 2, yielding $T_1 = \begin{array}{|c|c|c|c|} \hline 1 & 1 & 2 & 3 \\ \hline 2 & 5 & & \\ \hline 4 & & & \\ \hline \end{array}$. Reinserting the displaced 2 into the second row bumps out

the 5 to give $T_2 = \begin{array}{|c|c|c|c|} \hline 1 & 1 & 2 & 3 \\ \hline 2 & 2 & & \\ \hline 4 & & & \\ \hline \end{array}$. Reinserting this 5 in the third row gives $(T \leftarrow x) = \begin{array}{|c|c|c|c|} \hline 1 & 1 & 2 & 3 \\ \hline 2 & 2 & & \\ \hline 4 & 5 & & \\ \hline \end{array}$.

Definition 3.9. The *insertion tableau* of a word $w = w_1 w_2 \dots w_N$ is the tableau

$$\text{tab}(w) := (((\emptyset \leftarrow w_1) \leftarrow w_2) \leftarrow \dots \leftarrow w_N).$$

Theorem 3.10. Any word w satisfies $w \sim_K \text{word}(\text{tab}(w))$.

Corollary 3.11. $w \sim_K w'$ if and only if $\text{tab}(w) = \text{tab}(w')$

Proof. This is immediate from combining Theorems 3.6 and 3.10. □

Example 3.12. Theorem 3.10 makes sense when the elementary Knuth transformations are interpreted via row insertion. Let $w = yzx$ and $w' = yxz$ with $x < y \leq z$, so $w \sim_K w'$ via one use of (16). Direct computation shows that $\text{tab}(w) = \begin{array}{|c|c|} \hline x & z \\ \hline y & \\ \hline \end{array} = \text{tab}(w')$. Similarly, if

$v = zxy$ and $v' = xzy$ with $x \leq y < z$, then $\text{tab}(v) = \begin{array}{|c|c|} \hline x & y \\ \hline z & \\ \hline \end{array} = \text{tab}(v')$.

Definition 1.1 identifies a $M \in \text{Mat}_{m,n}(\mathbb{Z}_{\geq 0})$ with the pair $(\text{row}(M)|\text{col}(M))$. Combining this identification with the insertion algorithm yields:

Definition 3.13. The *RSK map* sends $M \in \text{Mat}_{m,n}(\mathbb{Z}_{\geq 0})$ to a pair of semistandard Young tableaux as follows: $\text{RSK}(M) = (\text{tab}(\text{row}(M))|\text{tab}(\text{col}(M)))$.

Theorem 3.14 (RSK Correspondence). The map *RSK* defines a bijection between $\text{Mat}_{m,n}(\mathbb{Z}_{\geq 0})$ and tableau-pairs $(P|Q)$ of the same shape λ .

Remark 3.15. In standard references such as [9], the map RSK is given by setting $P = \text{tab}(\text{col}(M))$ and defining Q to be a *recording tableau* that keeps track of information needed to reverse the insertion algorithm. The difficult part of the proof is showing that with these conventions we in fact have $Q = \text{tab}(\text{row}(M))$; this result is sometimes called the “symmetry theorem” [9, Section 4.1]. Instead, we prefer to see Theorem 3.14 as a consequence of more general results about crystal graphs; see Example 7.3.

Definition 3.16. Let w be a word with \mathbf{I} -filtration $\text{filter}_{\mathbf{I}}(w) = (w^{(1)}, \dots, w^{(r)})$. Then the *\mathbf{I} -filtered insertion tableau-tuple* of w is

$$\text{tab}_{\mathbf{I}}(w) = (\text{tab}(w^{(1)}), \text{tab}(w^{(2)}), \dots, \text{tab}(w^{(r)})).$$

In view of Definition 3.9, we obtain an algorithmic form of filterRSK :

Proposition 3.17. Given \mathbf{I} and \mathbf{J} as in (3) and $M \in \text{Mat}_{m,n}(\mathbb{Z}_{\geq 0})$

$$\text{filterRSK}_{\mathbf{I},\mathbf{J}}(M) = (\text{tab}_{\mathbf{I}}(\text{row}(M)), \text{tab}_{\mathbf{J}}(\text{col}(M))).$$

Proof. Immediate from Main Definition 1.5 and Theorem 3.10. □

4. CRYSTALS AND BICRYSTALS

To prove Theorem 1.11, we need a tool from Kashiwara’s theory of *crystal bases*, that is, special types of graphs called *crystal graphs*. We only need specific examples of crystal graphs and do not present the generalities. We refer to [26, 21, 3]. We begin by laying out just enough general notions for our needs.

Definition 4.1. A *pre-crystal graph* \mathcal{G} is a simple, directed graph with countably many labelled vertices and edges. The label of each vertex v has an associated *weight*, an ordered tuple of nonnegative integers denoted $\text{cwt}_{\mathcal{G}}(v) \in \mathbb{Z}_{\geq 0}^r$, for some fixed $r \in \mathbb{Z}_{\geq 0}$.

Definition 4.2. A *pre-crystal graph homomorphism* $f : \mathcal{G} \rightarrow \mathcal{H}$ is a weight-preserving set map between the vertex sets (so $\text{cwt}_{\mathcal{G}}(v) = \text{cwt}_{\mathcal{H}}(f(v))$ for all vertices $v \in \mathcal{G}$) that also preserves adjacency and edge labels. In other words, if $v \xrightarrow{i} v'$ in \mathcal{G} then we must have $f(v) \xrightarrow{i} f(v')$ in \mathcal{H} . Furthermore, f is a *pre-crystal graph isomorphism* if it is invertible and $f^{-1} : \mathcal{H} \rightarrow \mathcal{G}$ is also a pre-crystal graph homomorphism.

Definition 4.3. The *direct sum* $\mathcal{G} \oplus \mathcal{H}$ of two pre-crystal graphs is their disjoint union.

Definition 4.4. The *Cartesian product* $\mathcal{G} \square \mathcal{H}$ of two pre-crystal graphs has vertex set $\{(g, h) \mid g \in \mathcal{G}, h \in \mathcal{H}\}$, with $\text{cwt}_{\mathcal{G} \square \mathcal{H}}((g, h)) = (\text{cwt}_{\mathcal{G}}(g), \text{cwt}_{\mathcal{H}}(h))$. The edge-labels of $\mathcal{G} \square \mathcal{H}$ come from the disjoint union of the edge-labelling sets of \mathcal{G} and \mathcal{H} . There is an edge $(g, h) \xrightarrow{i^{\mathcal{G}}} (g', h')$ if $g \xrightarrow{i} g'$ and $h = h'$, and there is an edge $(g, h) \xrightarrow{j^{\mathcal{H}}} (g', h')$ if $g = g'$ and $h \xrightarrow{j} h'$.

Definition 4.5. A pre-crystal graph \mathcal{G} is *connected* if there exists an undirected path between any two vertices of \mathcal{G} (i.e., its underlying graph is connected).

Most pre-crystal graph homomorphisms we discuss will be of the following type:

Definition 4.6. A pre-crystal graph homomorphism $f : \mathcal{G} \rightarrow \mathcal{H}$ is a *local isomorphism* if its restriction $f|_{\mathcal{C}}$ to any connected component \mathcal{C} of \mathcal{G} is an isomorphism onto a connected component \mathcal{C}' of \mathcal{H} .

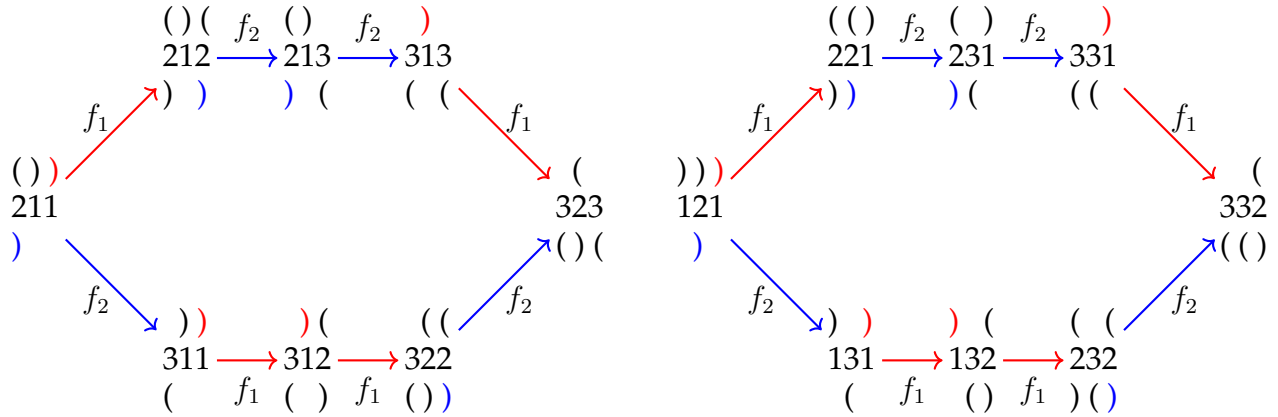

FIGURE 1. The connected components of \mathcal{W}_3 containing 211 and 121

Lemma 4.7.

- (I) If $f : \mathcal{G} \rightarrow \mathcal{H}$ is a local isomorphism then $\mathcal{G} \cong \bigoplus_c \mathcal{C}^{\oplus m_c}$, where the sum is over connected components of \mathcal{H} and m_c is the number of connected components of \mathcal{G} mapped onto \mathcal{C} by f .
- (II) A composition of local isomorphisms is a local isomorphism.
- (III) If $f : \mathcal{G} \rightarrow \mathcal{H}$ and $f' : \mathcal{G}' \rightarrow \mathcal{H}'$ are local isomorphisms, then the product map $(f \square f') : \mathcal{G} \square \mathcal{H} \rightarrow \mathcal{G}' \square \mathcal{H}'$ defined on vertices by $(v, v') \mapsto (f(v), f'(v'))$ is a local isomorphism.

Proof. (I) and (II) are immediate. (III) follows since connected components of $\mathcal{G} \square \mathcal{H}$ are of the form $\mathcal{G}' \square \mathcal{H}'$ where \mathcal{G}' and \mathcal{H}' are connected components of \mathcal{G} and \mathcal{H} , respectively. \square

4.1. Crystals of words and tableaux. Next, we define crystal graphs with vertices labelled by words. Let $w = w_1 w_2 \dots w_N$ be a word on the alphabet $[n]$ and fix $i \in [n - 1]$.

Definition 4.8. The i th bracket operator bracket_i associates a word on the alphabet $\{(,)\}$ to w by recording a “)” for each i and a “(” for each $i + 1$ (maintaining the order of the letters).

Definition 4.9. Let $w_e = i + 1$ and $w_f = i$ be the letters of w associated to the leftmost unmatched “(” and rightmost unmatched “)” of $\text{bracket}_i(w)$ respectively. The *crystal raising operator* e_i sends w to the word obtained by changing w_e to i . Analogously, the *crystal lowering operator* f_i sends w to the word obtained by changing w_f to $i + 1$. If no such letters w_e or w_f exist, the operators output the special symbol \emptyset .

Definition 4.10. The *word crystal graph* $\mathcal{W}_{[a,b]}$ has vertices labelled by words w on the alphabet $[a, b]$. The weight $\text{cwt}_{\mathcal{W}_{[a,b]}}(w)$ of a vertex w is $(y_a, y_{a+1}, \dots, y_b)$ where y_j is the number of j 's appearing in w . There is an edge $w \xrightarrow{i} v$ if and only if $v = f_i(w)$. In the case where $[a, b] = [1, n]$ we use the abbreviated notation $\mathcal{W}_n := \mathcal{W}_{[1,n]}$.

Example 4.11. Figure 1 shows the connected components of \mathcal{W}_3 containing 211 and 121. Each vertex is labelled by a word w , with $\text{bracket}_1(w)$ written above it and $\text{bracket}_2(w)$ below. We highlight the rightmost unmatched “)” in $\text{bracket}_1(w)$ using red (if it exists) and the rightmost unmatched “)” in $\text{bracket}_2(w)$ in blue. If $f_1(w) = v$, we draw a red edge directed from w to v , and when $f_2(w) = v$ we draw a blue edge directed from w to v . For clarity, we label the edges of the crystal graphs with “ f_i ” rather than “ i ”.

This lemma is well-known; we include a proof for convenience.

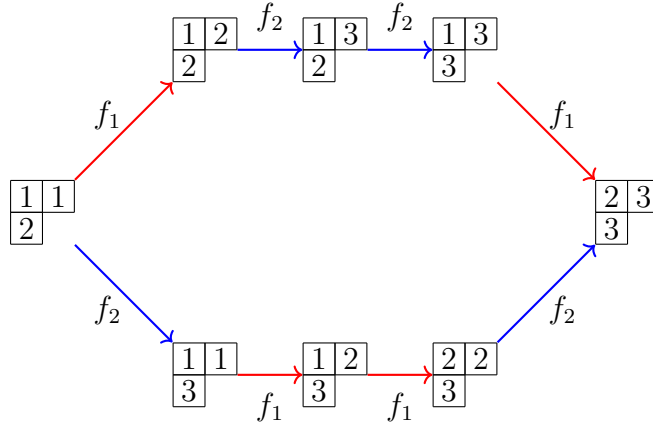

FIGURE 2. $B_{\lambda,3}$ for $\lambda = (2, 1)$

Lemma 4.12. *The crystal operators e_i and f_i are inverses whenever their outputs are not \emptyset .*

Proof. Removing all matched parentheses from $\text{bracket}_i(w)$ produces a string of the form $\dots)(\dots($. This shows that the rightmost unmatched “)” in $\text{bracket}_i(w)$ is in the same position as the leftmost unmatched “(” in $\text{bracket}_i(f_i(w))$ whenever $f_i(w) \neq \emptyset$. Similarly, the leftmost unmatched “(” in $\text{bracket}_i(w)$ is in the same position as the rightmost unmatched “)” in $\text{bracket}_i(e_i(w))$ whenever $e_i(w) \neq \emptyset$. \square

Definition 4.13. The *tableau crystal graph* $\mathcal{B}_{\lambda,[a,b]}$ is the induced subgraph of \mathcal{W}_n on the vertices $\{\text{word}(T) : T \in \text{SSYT}(\lambda, [a, b])\}$. We often use the abbreviation $\mathcal{B}_{\lambda,n} := \mathcal{B}_{\lambda,[1,n]}$.

We will typically refer to vertices of $\mathcal{B}_{\lambda,[a,b]}$ by tableaux rather than their reading words.

Definition 4.14. A word $w \in \mathcal{W}_{[a,b]}$ has *highest weight* if $e_i(w) = \emptyset$ for all i . Equivalently, w has highest weight if the vertex it labels in $\mathcal{W}_{[a,b]}$ is a source.

Theorem 4.15 ([26, Proposition 2.44]). *The graph $\mathcal{B}_{\lambda,[a,b]}$ is the connected component of $T_{\lambda,[a,b]}$ (Definition 1.10) in $\mathcal{W}_{[a,b]}$. This vertex is the unique source in $\mathcal{B}_{\lambda,[a,b]}$.*

Example 4.16. Figure 2 displays $\mathcal{B}_{\lambda,3}$ for $\lambda = (2, 1)$, which is the connected component of \mathcal{W}_3 containing 211 from Example 4.11 by Theorem 4.15.

Globally, $\mathcal{W}_{[a,b]}$ consists of copies of $\mathcal{B}_{\lambda,[a,b]}$ for various λ . The precise statement is Proposition 4.19, which we prove using two lemmas.

Lemma 4.17 (“coplactic” property of f_i and e_i , [3, Theorem 8.4]). *Fix two words w and w' on $[a, b]$ such that $w \sim_K w'$ and fix i . Then $f_i(w) \sim_K f_i(w')$ and $e_i(w) \sim_K e_i(w')$ (by convention, $\emptyset \sim_K \emptyset$). If $f_i(w), f_i(w') \neq \emptyset$ (resp. $e_i(w), e_i(w') \neq \emptyset$), then the converse holds.*

The following is also well-known. One reference is [21, Section 4]:

Lemma 4.18. *If $w \sim_K w'$, then w and w' do not lie in the same connected component of $\mathcal{W}_{[a,b]}$, unless $w = w'$.*

Proposition 4.19. *The map*

$$\text{tab} : \mathcal{W}_{[a,b]} \rightarrow \bigoplus_{\lambda} \mathcal{B}_{\lambda,[a,b]},$$

defined on vertices by $w \mapsto \text{tab}(w)$, is a local isomorphism.

Proof. (*tab is a pre-crystal graph homomorphism*): By definition, tab is weight-preserving. It remains to check adjacency is preserved under tab . Suppose $f_i(w) = w^\downarrow$, so $w \xrightarrow{i} w^\downarrow$ is an edge in $\mathcal{W}_{[a,b]}$. By Theorem 3.10, $w \sim_K \text{word}(\text{tab}(w))$ and $w^\downarrow \sim_K \text{word}(\text{tab}(w^\downarrow))$. Hence by Lemma 4.17 and Theorem 4.15 combined,

$$(18) \quad f_i(\text{word}(\text{tab}(w))) \sim_K w^\downarrow \sim_K \text{word}(\text{tab}(w^\downarrow)).$$

By Definition 4.13, (18) means $f_i(\text{tab}(w)) = \text{tab}(w^\downarrow)$, as desired.

(*tab is a local isomorphism*): Let \mathcal{G} be a connected component of $\mathcal{W}_{[a,b]}$. We claim the restricted map $\text{tab}|_{\mathcal{G}}$ is an isomorphism onto some $\mathcal{B}_{\lambda,[a,b]}$. To show injectivity, suppose $w, w' \in \mathcal{G}$ satisfy $\text{tab}(w) = \text{tab}(w')$. Then $w \sim_K w'$ by Corollary 3.11, so $w = w'$ by Lemma 4.18. To show surjectivity, suppose that for some $w \in \mathcal{G}$ and $T \in \mathcal{B}_{\lambda,[a,b]}$ there is an edge $\text{tab}(w) \xrightarrow{i} T$ in $\mathcal{B}_{\lambda,[a,b]}$. Then $\text{word}(T) = f_i(\text{word}(\text{tab}(w)))$, and since $w \sim_K \text{word}(\text{tab}(w))$ by Theorem 3.10, Lemma 4.17 immediately shows that $T = \text{tab}(f_i(w))$. Thus $\text{tab}|_{\mathcal{G}}$ is surjective, and this argument also shows that the inverse map $\text{tab}|_{\mathcal{G}}^{-1}$ on the vertices is a pre-crystal graph homomorphism. Thus $\text{tab}|_{\mathcal{G}}$ is a pre-crystal graph isomorphism onto $\mathcal{B}_{\lambda,[a,b]}$, so tab is a local isomorphism. \square

Corollary 4.20. *Any connected component \mathcal{G} of $\mathcal{W}_{[a,b]}$ has a unique source vertex v (i.e., a vertex of highest-weight). Moreover, $\text{tab}(v) = T_{\lambda,[a,b]}$ for some partition λ , and then $\mathcal{G} \cong \mathcal{B}_{\lambda,[a,b]}$.*

Proof. By Proposition 4.19, tab restricts to a pre-crystal graph isomorphism $\mathcal{G} \cong \mathcal{B}_{\lambda,[a,b]}$ for some λ . Now apply Theorem 4.15. \square

One can see that Figure 1 agrees with Proposition 4.19, Lemma 4.17, and Corollary 4.20.

Definition 4.21. The *Knuth crystal graph* $\mathcal{K}_{[a,b]}$ has vertices labelled by Knuth equivalence classes of words on $[a, b]$, with the weight of a class defined via representatives ($\text{cwt}_{\mathcal{K}_{[a,b]}}([w]_K) := \text{cwt}_{\mathcal{W}_{[a,b]}}(w)$). There is an edge $C \xrightarrow{i} C'$ if for some choice of representatives $C = [w]_K$ and $C' = [w']_K$, we have $w' = f_i(w)$. In other words, $\mathcal{K}_{[a,b]}$ is the quotient graph $\mathcal{W}_{[a,b]} / \sim_K$.

Since $w \sim_K w'$ implies $\text{cwt}_{\mathcal{W}_{[a,b]}}(w) = \text{cwt}_{\mathcal{W}_{[a,b]}}(w')$, $\text{cwt}_{\mathcal{K}_{[a,b]}}([w]_K)$ is well-defined.

Proposition 4.22. *The map*

$$[-]_K : \mathcal{W}_{[a,b]} \rightarrow \mathcal{K}_{[a,b]}$$

that sends $w \mapsto [w]_K$ is a local isomorphism. Thus, every connected component $\bar{\mathcal{G}}$ of $\mathcal{K}_{[a,b]}$ is isomorphic to $\mathcal{B}_{\lambda,[a,b]}$ for some λ .

Proof. From the definition of $\mathcal{K}_{[a,b]}$, $[-]_K$ is a pre-crystal graph homomorphism. Fix a connected component \mathcal{G} of $\mathcal{W}_{[a,b]}$. By Corollary 4.20, \mathcal{G} has a unique source vertex v and $\mathcal{G} \cong \mathcal{B}_{\lambda,[a,b]}$ where λ is the shape of $\text{tab}(v)$. Lemma 4.18 shows $[-]_K|_{\mathcal{G}}$ is injective. Now, suppose $[u]_K \xrightarrow{i} [w]_K$ is an edge in $\mathcal{K}_{[a,b]}$ for some $u \in \mathcal{G}$. By definition, there exists $u' \in [u]_K, w' \in [w]_K$ such that $u' \xrightarrow{i} w'$. By Lemma 4.17, $f_i(u) \sim_K f_i(u') = w'$. Hence $f_i(u) \in \mathcal{G}$ and $[f_i(u)]_K = [w']_K$. This proves that $[-]_K|_{\mathcal{G}}$ is surjective onto the connected component $\bar{\mathcal{G}}$ of $\mathcal{K}_{[a,b]}$ containing $[v]_K$, and also shows that the inverse map $([-]_K|_{\mathcal{G}})^{-1}$ is a pre-crystal graph homomorphism. Thus $[-]_K$ is a local isomorphism as desired.

For the second sentence, given $[w]_K \in \overline{\mathcal{G}}$, let \mathcal{G}_w be the connected component of $\mathcal{W}_{[a,b]}$ containing w . Then $\mathcal{G}_w \cong \mathcal{B}_{\lambda,[a,b]}$ for some λ by Corollary 4.20, and the first sentence of the lemma says $\mathcal{G}_w \cong \overline{\mathcal{G}}$. \square

Corollary 4.23. *The local isomorphism $\text{tab} : \mathcal{W}_{[a,b]} \rightarrow \bigoplus_{\lambda} \mathcal{B}_{\lambda,[a,b]}$ descends to a pre-crystal graph isomorphism*

$$\overline{\text{tab}} : \mathcal{K}_{[a,b]} \rightarrow \bigoplus_{\lambda} \mathcal{B}_{\lambda,[a,b]}.$$

Proof. Proposition 4.22 and Proposition 4.19 show that $\overline{\text{tab}}$ is a local isomorphism. It is clearly surjective. Finally, Corollary 3.11 shows that different connected components of $\mathcal{K}_{[a,b]}$ map to distinct $\mathcal{B}_{\lambda,[a,b]}$, so $\overline{\text{tab}}$ is a pre-crystal graph isomorphism. \square

4.2. Bicrystals of matrices. A matrix $M \in \text{Mat}_{m,n}(\mathbb{Z}_{\geq 0})$ is uniquely determined by $\text{row}(M)$ and $\text{col}(M)$ (Definition 1.1). In isolation, we understand these two “halves” of the information encoding M by Proposition 4.19. The connected components of \mathcal{W}_m and \mathcal{W}_n containing $\text{row}(M)$ and $\text{col}(M)$, respectively, are isomorphic to certain tableaux crystal graphs $\mathcal{B}_{\lambda,m}$ and $\mathcal{B}_{\mu,n}$ (in fact, $\lambda = \mu$ by Remark 3.15). This subsection is about the “bicrystal” structure, due to [5, 30], on $\text{Mat}_{m,n}(\mathbb{Z}_{\geq 0})$ that intermingles the two “halves”.

Definition 4.24. Let $M = [m_{i,j}] \in \text{Mat}_{m,n}(\mathbb{Z}_{\geq 0})$, and let $(i+1, b)$ and (i, a) be the coordinates of the entries of M yielding the letters of $\text{row}(M)$ altered by e_i and f_i respectively. The *row crystal raising operator* e_i^{row} sends M to the matrix $e_i^{\text{row}}(M)$ obtained by subtracting one from $m_{i+1,b}$ and adding one to $m_{i,b}$. Similarly, the *row crystal lowering operator* f_i^{row} sends M to the matrix $f_i^{\text{row}}(M)$ obtained by subtracting one from $m_{i,a}$ and adding one to $m_{i+1,a}$. When $e_i(\text{row}(M)) = \emptyset$ or $f_i(\text{row}(M)) = \emptyset$, we define the corresponding row bicrystal operators to output the special symbol \emptyset instead of a matrix. The *column bicrystal operators* e_j^{col} and f_j^{col} are defined analogously using $\text{col}(M)$ (or using transposes: $e_j^{\text{col}}(M) = (e_j^{\text{row}}(M^t))^t$ and $f_j^{\text{col}}(M) = (f_j^{\text{row}}(M^t))^t$).

Definition 4.25. The *matrix bicrystal graph* $\mathcal{M}_{m,n}$ is a pre-crystal graph with vertices $M \in \text{Mat}_{m,n}(\mathbb{Z}_{\geq 0})$ with weights

$$\text{cwt}_{\mathcal{M}_{m,n}}(M) := (\text{cwt}_{\mathcal{W}_m}(\text{row}(M)), \text{cwt}_{\mathcal{W}_n}(\text{col}(M))) \in \mathbb{Z}^{m+n}.$$

There is an i^{row} -labelled edge from M to M' if and only if $M' = f_i^{\text{row}}(M)$. There is a j^{col} -labelled edge from M to M' if and only if $M' = f_j^{\text{col}}(M)$.

Definition 4.26. Let $\mathcal{M}_{m,n}^{\text{row}}$ and $\mathcal{M}_{m,n}^{\text{col}}$ to be the pre-crystal subgraphs of $\mathcal{M}_{m,n}$ using only i^{row} -labelled or j^{col} -labelled edges respectively. Set

$$\text{cwt}_{\mathcal{M}_{m,n}^{\text{row}}}(M) := \text{cwt}_{\mathcal{W}_m}(\text{row}(M)), \quad \text{cwt}_{\mathcal{M}_{m,n}^{\text{col}}}(M) := \text{cwt}_{\mathcal{W}_n}(\text{col}(M)).$$

Example 4.27. Figure 3 depicts the connected component \mathcal{H} of $\begin{bmatrix} 1 & 1 & 0 \\ 1 & 0 & 0 \\ 0 & 0 & 0 \end{bmatrix}$ in $\mathcal{M}_{3,3}^{\text{row}}$. A red arrow from M to M' indicates that $M' = f_1^{\text{row}}(M)$ and a blue arrow indicates that $M' = f_2^{\text{row}}(M)$. Notice $\mathcal{H} \cong \mathcal{B}_{\square,3}$ is a pre-crystal graph isomorphism, under the map $M \mapsto \text{tab}(\text{row}(M))$. This is an instance of Lemma 4.28 (below) combined with Proposition 4.19.

Lemma 4.28. *The maps*

$$\text{row} : \mathcal{M}_{m,n}^{\text{row}} \rightarrow \mathcal{W}_m \quad \text{and} \quad \text{col} : \mathcal{M}_{m,n}^{\text{col}} \rightarrow \mathcal{W}_n,$$

defined on vertices by $M \mapsto \text{row}(M)$ and $M \mapsto \text{col}(M)$ respectively are local isomorphisms.

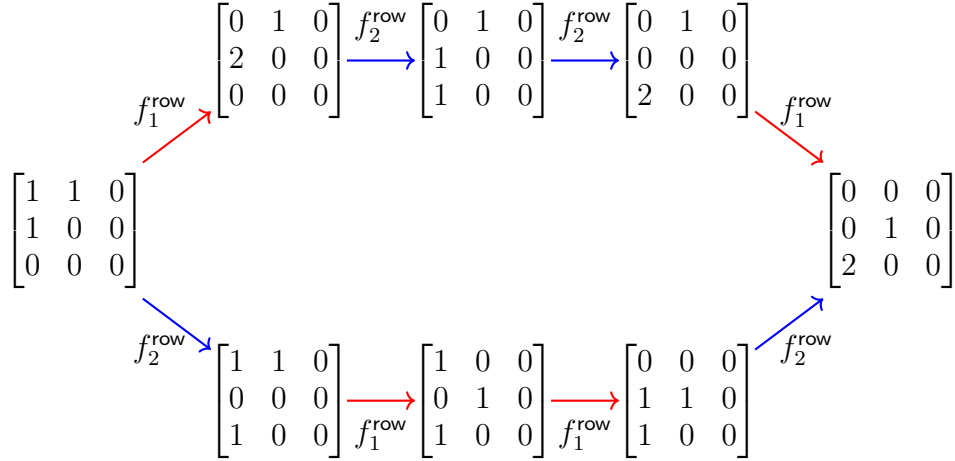

FIGURE 3. A connected component \mathcal{H} of $\mathcal{M}_{3,3}^{\text{row}}$

Proof. We prove that row is a local isomorphism; the argument for col is entirely analogous.

(row is a pre-crystal graph homomorphism): By definition, row is weight-preserving. Now, the row bicrystal operators are defined such that $\text{row}(f_i^{\text{row}}(M)) = f_i(\text{row}(M))$. This means that row preserves adjacency.

(row is a local isomorphism): Fix a connected component \mathcal{G} of $\mathcal{M}_{m,n}^{\text{row}}$. Fix $M_0 \in \mathcal{G}$. We must show $\text{row}|_{\mathcal{G}}$ is an isomorphism onto the connected component \mathcal{H} of \mathcal{W}_m that contains $\text{row}(M_0)$. To see injectivity, let $M \in \mathcal{G}$ be arbitrary. Since M_0 and M are connected by row bicrystal operations, it follows from the definitions that $\text{cwt}_{\mathcal{W}_n}(\text{col}(M)) = \text{cwt}_{\mathcal{W}_n}(\text{col}(M_0))$. Now, any matrix $U \in \text{Mat}_{m,n}(\mathbb{Z}_{\geq 0})$ is uniquely reconstructible from $\text{row}(U)$ and $\text{cwt}_{\mathcal{W}_n}(\text{col}(U))$. Thus M is uniquely identified in \mathcal{G} by its row word, so the restriction $\text{row}|_{\mathcal{G}}$ is injective. To show surjectivity, suppose there is an edge $\text{row}(M) \xrightarrow{i} w$ in \mathcal{H} . Then $f_i(\text{row}(M)) = w$, so by the definition of the row bicrystal operators, $w = \text{row}(f_i^{\text{row}}(M))$. Thus $\text{row}|_{\mathcal{G}}$ is surjective onto \mathcal{H} , and this argument also shows that the inverse map $\text{row}|_{\mathcal{G}}^{-1}$ is a pre-crystal graph homomorphism. Hence, $\text{row}|_{\mathcal{G}}$ is an isomorphism onto \mathcal{H} and row is a local isomorphism. \square

Given Lemma 4.28, one might expect a local isomorphism $\mathcal{M}_{m,n} \rightarrow \mathcal{W}_m \square \mathcal{W}_n$ defined by $M \mapsto (\text{row}(M)|\text{col}(M))$. However, this map is not a pre-crystal graph homomorphism (in general, $f_i^{\text{row}}(M) \not\mapsto (f_i(\text{row}(M)|\text{col}(M)))$). On the other hand, Proposition 4.31 shows that we *do* obtain a local isomorphism when we replace $\mathcal{W}_m \square \mathcal{W}_n$ with the quotient graph $\mathcal{K}_m \square \mathcal{K}_n$. To establish this result, we need the next two (known) lemmas. They can be proved via careful but elementary analysis of the matrix bicrystal operators.

Lemma 4.29 ([30, Proposition 5.8]). *Let $M \in \text{Mat}_{m,n}(\mathbb{Z}_{\geq 0})$. Then*

$$\text{col}(e_i^{\text{row}}(M)) \sim_K \text{col}(M) \sim_K \text{col}(f_i^{\text{row}}(M)),$$

assuming $e_i^{\text{row}}(M) \neq \emptyset$ and $f_i^{\text{row}}(M) \neq \emptyset$ for the two equivalences respectively. Similarly,

$$\text{row}(e_j^{\text{col}}(M)) \sim_K \text{row}(M) \sim_K \text{row}(f_j^{\text{col}}(M)),$$

assuming $e_j^{\text{col}}(M) \neq \emptyset$ and $f_j^{\text{col}}(M) \neq \emptyset$ for the two equivalences respectively.

Lemma 4.30 ([30, Lemma 1.4.7]). *The row and column bicrystal operators on $M \in \text{Mat}_{m,n}(\mathbb{Z}_{\geq 0})$ commute. That is, for all i and j ,*

$$\begin{aligned} f_i^{\text{row}}(f_j^{\text{col}}(M)) &= f_j^{\text{col}}(f_i^{\text{row}}(M)), & e_i^{\text{row}}(e_j^{\text{col}}(M)) &= e_j^{\text{col}}(e_i^{\text{row}}(M)) \\ e_i^{\text{row}}(f_j^{\text{col}}(M)) &= f_j^{\text{col}}(e_i^{\text{row}}(M)), & f_i^{\text{row}}(e_j^{\text{col}}(M)) &= e_j^{\text{col}}(f_i^{\text{row}}(M)). \end{aligned}$$

Proposition 4.31 below is essentially classical RSK, associating $M \in \text{Mat}_{m,n}(\mathbb{Z}_{\geq 0})$ to pairs of Knuth equivalence classes (which can then be labelled uniquely with tableaux). However, the local isomorphism reformulation will be convenient in the sequel.

Proposition 4.31. *The map*

$$\text{biword} : \mathcal{M}_{m,n} \rightarrow \mathcal{K}_m \square \mathcal{K}_n,$$

defined by $M \mapsto ([\text{row}(M)]_K \mid [\text{col}(M)]_K)$, is a local isomorphism.

Proof. (biword is a pre-crystal graph homomorphism): By definition, biword is a weight-preserving map. It remains to check that it preserves adjacency. Suppose $M \xrightarrow{i^{\text{row}}} M'$ is an edge in $\mathcal{M}_{m,n}$. By Lemma 4.29, $[\text{col}(M)]_K = [\text{col}(M')]_K$. By Lemma 4.28, $\text{row}(M) \xrightarrow{i} \text{row}(M')$ in \mathcal{W}_m . Therefore, by Definition 4.21, $[\text{row}(M)]_K \xrightarrow{i} [\text{row}(M')]_K$ in \mathcal{K}_m . Thus, $\text{biword}(M) \xrightarrow{i^{\text{row}}} \text{biword}(M')$ is an edge in $\mathcal{K}_m \square \mathcal{K}_n$. The argument for an edge $M \xrightarrow{j^{\text{col}}} M'$ is similar.

(biword is a local isomorphism): Let \mathcal{G} be a connected component of $\mathcal{M}_{m,n}$. Fix $M_0 \in \mathcal{G}$.

We show $\text{biword}|_{\mathcal{G}}$ is injective. Suppose $M_1, M_2 \in \mathcal{G}$ and $\text{biword}(M_1) = \text{biword}(M_2)$. Fix a path \mathcal{P}_1 from M_0 to M_1 , and a path \mathcal{P}_2 from M_0 to M_2 . By Lemma 4.30, we may assume that \mathcal{P}_1 starts with a subpath from M_0 to some M'_1 lying entirely in $\mathcal{M}_{m,n}^{\text{row}}$ followed by a subpath from M'_1 to M_1 lying entirely in $\mathcal{M}_{m,n}^{\text{col}}$. Similarly, one defines M'_2 . Hence M'_1 and M'_2 both lie in the connected component of M_0 in $\mathcal{M}_{m,n}^{\text{row}}$. Moreover, by Lemma 4.29, $\text{row}(M'_1) \sim_K \text{row}(M_1)$ and $\text{row}(M'_2) \sim_K \text{row}(M_2)$. Since $\text{row}(M_1) \sim_K \text{row}(M_2)$ by assumption, we see that $\text{row}(M'_1) \sim_K \text{row}(M'_2)$ by transitivity. Thus, $M'_1 = M'_2$ by Lemma 4.28 and Lemma 4.18. Now, M_1 and M_2 both lie in the connected component of $M'_1 = M'_2$ in $\mathcal{M}_{m,n}^{\text{col}}$. Since $\text{col}(M_1) \sim_K \text{col}(M_2)$ by assumption, Lemma 4.28 and Lemma 4.18 imply that $M_1 = M_2$. Thus $\text{biword}|_{\mathcal{G}}$ is injective.

To show surjectivity, suppose $\text{biword}(M) \xrightarrow{i^{\mathcal{K}_m}} ([u]_K \mid [\text{col}(M)]_K)$ is an edge in $\mathcal{K}_m \square \mathcal{K}_n$ for some $M \in \mathcal{G}$ (the case $\text{biword}(M) \xrightarrow{j^{\mathcal{K}_n}} ([\text{row}(M)]_K \mid [v]_K)$ is similar). Thus, there exists an edge $[\text{row}(M)]_K \xrightarrow{i} [u]_K$ in \mathcal{K}_m . By Lemma 4.28, the connected component of $\mathcal{M}_{m,n}^{\text{row}}$ containing M is isomorphic to the connected component of \mathcal{W}_m containing $\text{row}(M)$ which in turn is isomorphic, by Proposition 4.22, to the connected component of \mathcal{K}_m containing $[\text{row}(M)]_K$. From this, one sees there is an edge $M \xrightarrow{i^{\text{row}}} M'$ in $\mathcal{M}_{m,n}$ such that $\text{biword}(M') = ([u]_K \mid [\text{col}(M)]_K)$. Thus $\text{biword}|_{\mathcal{G}}$ is surjective onto the connected component \mathcal{H} of $\mathcal{K}_m \square \mathcal{K}_n$ that contains $\text{biword}(M_0)$. It follows that $\text{biword}|_{\mathcal{G}} : \mathcal{G} \rightarrow \mathcal{H}$ is a bijection of vertices, and this argument also shows that $\text{biword}|_{\mathcal{G}}^{-1}$ preserves adjacency, completing the proof. \square

Proposition 4.31 encapsulates our claim from the introduction that the bicrystal operators on matrices are a “pull-back” of the crystal operators on words. We illustrate the point with the commutative cube in Figure 4.

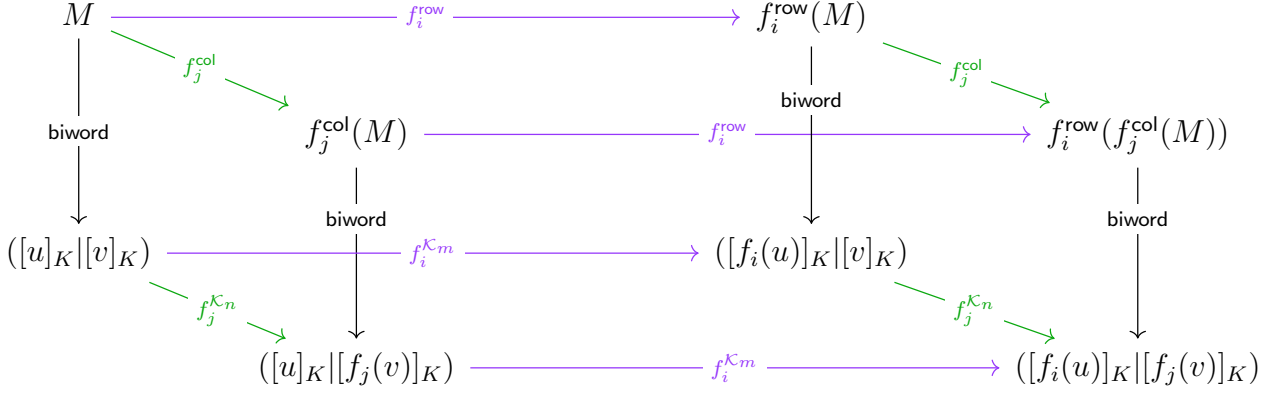

FIGURE 4. An illustration of Proposition 4.31, where $u = \text{row}(M)$ and $v = \text{col}(M)$.

5. FILTERINGS AND THE PROOF OF THEOREM 1.11

This section shows how the results of Section 4.1 generalize using the $\text{filterRSK}_{\mathbf{I}, \mathbf{J}}$ map, leading to our proof of Theorem 1.11. As in (3), fix sequences of nonnegative integers

$$\mathbf{I} = \{0 = i_0 < \dots < i_r = m\} \quad \text{and} \quad \mathbf{J} = \{0 = j_0 < \dots < j_s = n\}.$$

Definition 5.1. The \mathbf{I} -filtered word crystal graph $\mathcal{W}_m^{\mathbf{I}}$ is the subgraph of \mathcal{W}_m obtained by deleting all edges labelled by elements $i \in \mathbf{I}$.

Proposition 5.2. Let \mathbf{I} be as in (3). The map $\text{filter}_{\mathbf{I}} : \mathcal{W}_m^{\mathbf{I}} \rightarrow \mathcal{W}_{[1, i_1]} \square \mathcal{W}_{[i_1+1, i_2]} \square \dots \square \mathcal{W}_{[i_{r-1}+1, m]}$, defined on vertices by $w \mapsto \text{filter}_{\mathbf{I}}(w)$, is a local isomorphism.

Let us emphasize that $\text{filter}_{\mathbf{I}}$ is not an isomorphism. For example, if $m = 2$ and $\mathbf{I} = \{0, 1, 2\}$ then $\text{filter}_{\mathbf{I}}(12) = \text{filter}_{\mathbf{I}}(21) = (1, 2)$.

Proof. ($\text{filter}_{\mathbf{I}}$ is a pre-crystal graph homomorphism): By Definition 4.4,

$$\text{cwt}_{\mathcal{W}_{[1, i_1]} \square \dots \square \mathcal{W}_{[i_{r-1}+1, m]}}(\text{filter}_{\mathbf{I}}(w)) = (\text{cwt}_{\mathcal{W}_{[1, i_1]}}(w^{(1)}), \dots, \text{cwt}_{\mathcal{W}_{[i_{r-1}+1, m]}}(w^{(r)})) = \text{cwt}_{\mathcal{W}_m^{\mathbf{I}}}(w).$$

Hence $\text{filter}_{\mathbf{I}}$ is weight-preserving.

Now we show that $\text{filter}_{\mathbf{I}}$ preserves adjacency. Suppose $w \xrightarrow{i} w'$ is an edge in $\mathcal{W}_m^{\mathbf{I}}$. By definition, $\text{filter}_{\mathbf{I}}(w')$ and $\text{filter}_{\mathbf{I}}(w)$ agree in each component except the k -th, where $i_{k-1} + 1 \leq i \leq i_k$. In that component, $w^{(k)} = f_i(w^{(k)})$. That is, $w^{(k)} \xrightarrow{i} w'^{(k)}$ is an edge in $\mathcal{W}_{[i_{k-1}+1, i_k]}$. Thus, by Definition 4.4, $\text{filter}_{\mathbf{I}}(w) \xrightarrow{i} \text{filter}_{\mathbf{I}}(w')$ is an edge in the Cartesian product pre-crystal graph $\mathcal{W}_{[1, i_1]} \square \mathcal{W}_{[i_1+1, i_2]} \square \dots \square \mathcal{W}_{[i_{r-1}+1, m]}$, as required.

($\text{filter}_{\mathbf{I}}$ is a local isomorphism): Fix \mathcal{G} a connected component of $\mathcal{W}_m^{\mathbf{I}}$ and $w_0 \in \mathcal{G}$. We need to show that $\text{filter}_{\mathbf{I}}$ restricts to an isomorphism $\mathcal{G} \rightarrow \mathcal{G}^{(1)} \square \dots \square \mathcal{G}^{(k)}$, where $\mathcal{G}^{(k)}$ is the connected component of $\mathcal{W}_{[i_{k-1}+1, i_k]}$ containing $w_0^{(k)}$.

First we show that $\text{filter}_{\mathbf{I}}|_{\mathcal{G}}$ is injective. Suppose $\text{filter}_{\mathbf{I}}|_{\mathcal{G}}(u) = \text{filter}_{\mathbf{I}}|_{\mathcal{G}}(v) = (\pi^{(1)}, \dots, \pi^{(r)})$ for some $u, v \in \mathcal{G}$. Both u and v are interweavings of the words $\pi^{(1)}, \dots, \pi^{(r)}$, i.e., the letters appearing in $\pi^{(t)}$ are in the same order in both u and v , but in possibly different positions. However, any sequence of crystal operations f_i, e_i ($i \notin \mathbf{I}$) applied to u does not

affect the set of positions of u that are occupied by $[i_{t-1} + 1, i_t]$. Hence u and v cannot be in the same connected component unless $u = v$.

For surjectivity, suppose $\text{filter}_{\mathbf{I}}(w) \xrightarrow{i} \alpha$ is an edge in $\mathcal{W}_{[1, i_1]} \square \mathcal{W}_{[i_1+1, i_2]} \square \cdots \square \mathcal{W}_{[i_{r-1}+1, m]}$ for some $w \in \mathcal{G}$, where $i \notin \mathbf{I}$. Suppose k is the unique index such that $i \in [i_{k-1} + 1, i_k]$. Since $\text{bracket}_i(w) = \text{bracket}_i(w^{(k)})$, clearly $\text{filter}_{\mathbf{I}}(f_i(w)) = \alpha$.

Thus, the inverse map $(\text{filter}_{\mathbf{I}}|_{\mathcal{G}})^{-1}$ exists and preserves adjacency as required. \square

Taking the quotient of $\mathcal{W}_m^{\mathbf{I}}$ by \sim_K produces the \mathbf{I} -filtered Knuth crystal graph $\mathcal{K}_m^{\mathbf{I}}$. We now show that $\text{filter}_{\mathbf{I}}$ descends to a local isomorphism on these quotients.

Corollary 5.3. *Let \mathbf{I} be as in (3). The map*

$$\overline{\text{filter}}_{\mathbf{I}} : \mathcal{K}_m^{\mathbf{I}} \rightarrow \mathcal{K}_{[1, i_1]} \square \cdots \square \mathcal{K}_{[i_{r-1}+1, m]},$$

defined on vertices using representatives ($[w]_K \mapsto [\text{filter}_{\mathbf{I}}(w)]_K$), is a local isomorphism.

Proof. ($\overline{\text{filter}}_{\mathbf{I}}$ is well-defined): We need that $w \sim_K w'$ implies $\text{filter}_{\mathbf{I}}(w) \sim_K \text{filter}_{\mathbf{I}}(w')$ (where Knuth equivalence of filtered words is defined component-wise). The only elementary Knuth moves (16), (17) on w that alter $\text{filter}_{\mathbf{I}}(w)$ are those swapping two elements $x, z \in [i_{k-1} + 1, i_k]$ for some $1 \leq k \leq r$. Such a move is of the form $xzy \leftrightarrow zxy$ or $yxz \leftrightarrow yzx$ for $y \in [i_{k-1} + 1, i_k]$, and is therefore also an elementary Knuth move on $w^{(k)}$, as desired.

($\overline{\text{filter}}_{\mathbf{I}}$ is a local isomorphism): Fix a connected component $\overline{\mathcal{G}}$ of $\mathcal{K}_m^{\mathbf{I}}$ and a vertex σ_0 in $\overline{\mathcal{G}}$. Pick a representative w_0 for σ_0 . $\overline{\mathcal{G}}$ is isomorphic to the connected component \mathcal{G} of $\mathcal{W}_m^{\mathbf{I}}$ containing w_0 , by Proposition 4.22. The proof follows from the commuting diagram:

$$\begin{array}{ccc} \mathcal{G} & \xleftarrow[\cong]{\text{filter}_{\mathbf{I}}} & \mathcal{G}_1 \square \mathcal{G}_2 \square \cdots \square \mathcal{G}_r \\ \uparrow \cong & & \uparrow \cong \\ [-]_K & & [-]_K \square [-]_K \square \cdots \square [-]_K \\ \downarrow \cong & & \downarrow \cong \\ \overline{\mathcal{G}} & \xrightarrow[\text{filter}_{\mathbf{I}}]{\text{---}} & \overline{\mathcal{G}}_1 \square \overline{\mathcal{G}}_2 \square \cdots \square \overline{\mathcal{G}}_r \end{array}$$

By Proposition 5.2, $\text{filter}_{\mathbf{I}}|_{\mathcal{G}}$ is an isomorphism from \mathcal{G} to the product graph $\mathcal{G}_1 \square \mathcal{G}_2 \square \cdots \square \mathcal{G}_r$, where \mathcal{G}_k is the connected component of $w_0^{(k)}$ in $\mathcal{W}_{[i_{k-1}+1, i_k]}$. By Proposition 4.22, taking Knuth equivalence classes of filtered words then gives a third isomorphism from $\mathcal{G}_1 \square \mathcal{G}_2 \square \cdots \square \mathcal{G}_r$ to the quotient graph $\overline{\mathcal{G}}_1 \square \overline{\mathcal{G}}_2 \square \cdots \square \overline{\mathcal{G}}_r$ in $\mathcal{K}_{[1, i_1]} \square \cdots \square \mathcal{K}_{[i_{r-1}+1, m]}$. \square

Definition 5.4. The $(\mathbf{I}|\mathbf{J})$ -filtered matrix bicrystal graph $\mathcal{M}_{m,n}^{\mathbf{I}|\mathbf{J}}$ is the subgraph of $\mathcal{M}_{m,n}$ obtained by deleting all edges i^{row} with $i \in \mathbf{I}$ and j^{col} with $j \in \mathbf{J}$.

Definition 5.5. An $(\mathbf{I}$ -filtered) partition-tuple is a sequence of partitions $\underline{\lambda} = (\lambda^{(1)}, \dots, \lambda^{(r)})$, where each $\lambda^{(k)}$ has at most $i_k - i_{k-1}$ rows. An $(\mathbf{I}$ -filtered) tableau-tuple of shape $\underline{\lambda}$ is an ordered sequence of tableaux $\underline{T} = (T^{(1)}, \dots, T^{(r)})$ with each $T^{(k)} \in \text{SSYT}(\lambda^{(k)}, [i_{k-1} + 1, i_k])$.

Definition 5.6. Let $\underline{\lambda} = (\lambda^{(1)}, \dots, \lambda^{(r)})$ be an \mathbf{I} -filtered partition-tuple. The \mathbf{I} -filtered tableau crystal graph $\mathcal{B}_{\underline{\lambda}, m}^{\mathbf{I}}$ is the Cartesian product $\mathcal{B}_{\lambda^{(1)}, [1, i_1]} \square \mathcal{B}_{\lambda^{(2)}, [i_1+1, i_2]} \square \cdots \square \mathcal{B}_{\lambda^{(r)}, [i_{r-1}+1, m]}$.

We can now show that the map $\text{filterRSK}_{\mathbf{I}|\mathbf{J}}$ of Definition 1.5 is a local isomorphism.

Proposition 5.7. *Let \mathbf{I} and \mathbf{J} be as in (3). Then the map*

$$\text{filterRSK}_{\mathbf{I}|\mathbf{J}} : \mathcal{M}_{m,n}^{\mathbf{I}|\mathbf{J}} \rightarrow \bigoplus_{\underline{\lambda}, \underline{\mu}} (\mathcal{B}_{\underline{\lambda}, m} \square \mathcal{B}_{\underline{\mu}, n}),$$

given on vertices by mapping $M \mapsto \text{filterRSK}_{\mathbf{I}|\mathbf{J}}(M)$, is a local isomorphism.

Proof. By Proposition 4.31, $\text{biword} : \mathcal{M}_{m,n} \rightarrow \mathcal{K}_m \square \mathcal{K}_n$ is a local isomorphism. It follows immediately (from the proof) that $\text{biword} : \mathcal{M}_{m,n}^{\mathbf{I}|\mathbf{J}} \rightarrow \mathcal{K}_m^{\mathbf{I}} \square \mathcal{K}_n^{\mathbf{J}}$ (defined the same on vertices) is also a local isomorphism, since on both the domain and codomain we are simply deleting all edges with labels in \mathbf{I} or \mathbf{J} .

We may then understand $\text{filterRSK}_{\mathbf{I}|\mathbf{J}}$ as a composition of the maps $\text{biword} : \mathcal{M}_{m,n}^{\mathbf{I}|\mathbf{J}} \rightarrow \mathcal{K}_m^{\mathbf{I}} \square \mathcal{K}_n^{\mathbf{J}}$, $\overline{\text{filter}}_{\mathbf{I}} : \mathcal{K}_m^{\mathbf{I}} \rightarrow \mathcal{K}_{[1, i_1]} \square \mathcal{K}_{[i_1+1, i_2]} \square \cdots \square \mathcal{K}_{[i_{r-1}+1, m]}$, and $\overline{\text{tab}} : \mathcal{K}_{[a, b]} \rightarrow \bigoplus_{\lambda} \mathcal{B}_{\lambda, [a, b]}$. These three maps are local isomorphisms by the previous paragraph, Corollary 5.3, and Corollary 4.23 respectively. Now apply Lemma 4.7, parts (II) and (III). \square

Corollary 5.8. *Any connected component \mathcal{G} of $\mathcal{M}_{m,n}^{\mathbf{I}|\mathbf{J}}$ has a unique source vertex M (i.e., a vertex of highest-weight). Moreover, $\text{filterRSK}_{\mathbf{I}|\mathbf{J}}(M) = (T_{\underline{\lambda}} | T_{\underline{\mu}})$ for some partition-tuples $\underline{\lambda}$ and $\underline{\mu}$, and then $\mathcal{G} \cong \mathcal{B}_{\underline{\lambda}, m} \square \mathcal{B}_{\underline{\mu}, n}$.*

Proof. By Proposition 5.7, filterRSK restricts to an isomorphism $\mathcal{G} \cong \mathcal{B}_{\underline{\lambda}, m} \square \mathcal{B}_{\underline{\mu}, n}$ for some $\underline{\lambda}$ and $\underline{\mu}$. Now apply Theorem 4.15 along with the fact that any source vertex in a Cartesian product of graphs is given by a product of source vertices in each factor. \square

Theorem 5.9 (Bicrystal categorification of Theorem 1.11). *If $\mathfrak{X} \subseteq \text{Mat}_{m,n}$ is $\mathbf{L}_{\mathbf{I}|\mathbf{J}}$ -bicrystal closed, then the monomials in $\text{Std}_{<}(S/I(\mathfrak{X}))$ (interpreted as matrices) are vertices of an induced pre-crystal subgraph $\mathcal{S}_{\mathfrak{X}}$ of $\mathcal{M}_{m,n}^{\mathbf{I}|\mathbf{J}}$. Now $\text{filterRSK}_{\mathbf{I}|\mathbf{J}}$ gives a pre-crystal graph isomorphism*

$$(19) \quad \mathcal{S}_{\mathfrak{X}} \cong \bigoplus_{\underline{\lambda}|\underline{\mu}} (\mathcal{B}_{\underline{\lambda}, m} \square \mathcal{B}_{\underline{\mu}, n})^{\oplus c_{\underline{\lambda}|\underline{\mu}}^{\mathfrak{X}}},$$

where the sum is over all partition-tuples $(\underline{\lambda}|\underline{\mu})$. The multiplicities $c_{\underline{\lambda}|\underline{\mu}}^{\mathfrak{X}}$ counts highest-weight matrices $M \in \text{Std}_{<}(S/I(\mathfrak{X}))$ of shape $(\underline{\lambda}|\underline{\mu})$.

Proof. The first sentence is by the definition of \mathfrak{X} being $\mathbf{L}_{\mathbf{I}|\mathbf{J}}$ -bicrystal closed. Any pre-crystal graph is the disjoint union of its connected components; the hypothesis of being $\mathbf{L}_{\mathbf{I}|\mathbf{J}}$ -bicrystal closed says that a connected component \mathcal{G} of $\mathcal{S}_{\mathfrak{X}}$ is a connected component of $\mathcal{M}_{m,n}^{\mathbf{I}|\mathbf{J}}$. Therefore, we are done by Proposition 5.7, Lemma 4.7(I), and Corollary 5.8. \square

Proof of Theorem 1.11: Section 2 and specifically Proposition 2.17 implies (8), since each standard monomial m spans a weight space with weight $\text{wt}(m)$ with respect to the algebraic torus action of $\mathbf{T} = (\mathbb{C}^*)^m \times (\mathbb{C}^*)^n$ (see Section 2.3). Now, the result follows from Theorem 5.9 combined with the hypothesis that \mathfrak{X} is $\mathbf{L}_{\mathbf{I}|\mathbf{J}}$ -bicrystalline. Specifically, in that theorem, the pre-crystal graph isomorphism is, by definition, weight-preserving. These weights agree with $\text{wt}_{\mathbf{T}}(m)$ and the weight of semistandard tableau in its contribution to a Schur polynomial. Thus the equality in (9) follows from the isomorphism. \square

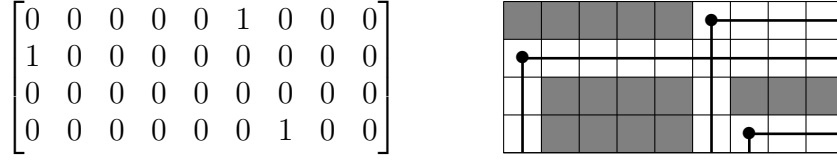

FIGURE 5. The partial permutation matrix M_w for $w = 61\infty 7$ and its Rothe diagram; the boxes of $\bar{D}(w)$ are shaded.

6. MAIN APPLICATION: MATRIX SCHUBERT VARIETIES

6.1. Matrix Schubert varieties. Let $B_k \subset GL_k$ denote the Borel group of lower triangular matrices. Then $\mathbf{B} = B_m \times B_n$ acts on $\text{Mat}_{m,n}$ on the right by $(b_1, b_2) \cdot M = b_1^{-1} M (b_2^{-1})^T$. We recount the construction of all \mathbf{B} -stable varieties in $\text{Mat}_{m,n}$ due to Fulton [8].

Definition 6.1. A *partial permutation matrix* $M_w \in \text{Mat}_{m,n}$ is a matrix with at most one 1 in each row and column and 0s everywhere else. The indexing *partial permutation* is a function $w : [m] \rightarrow [n] \cup \{\infty\}$, where $w(i) = j \in [n]$ if M_w has a 1 in position (i, j) and $w(i) = \infty$ if M_w has no 1 in row i . The *rank function* for M_w is denoted $r_w : [m] \times [n] \rightarrow \mathbb{Z}_{\geq 0}$; it maps (i, j) to the rank of the northwest $i \times j$ submatrix of M_w .

Theorem 6.2 ([8, Lemma 3.1]). *Every \mathbf{B} -orbit in $\text{Mat}_{m,n}$ contains a unique M_w .*

Definition-Theorem 6.3 ([8, Proposition 3.3]). *The matrix Schubert variety $\mathfrak{X}_w \subseteq \text{Mat}_{m,n}$ is the Zariski closure of the orbit $\mathbf{B} \cdot M_w$. Each \mathfrak{X}_w is irreducible.*

The following immediate consequence of Definition-Theorem 6.3 is known:

Corollary 6.4. *Any \mathbf{B} -stable variety $\mathfrak{X} \subseteq \text{Mat}_{m,n}$ is a finite union of matrix Schubert varieties.*

Proof. There are only finitely many partial permutation matrices in $\text{Mat}_{m,n}$. Now apply Theorem 6.2 and Definition-Theorem 6.3. \square

In light of Corollary 6.4, we restrict our attention to matrix Schubert varieties $\mathfrak{X}_w \subseteq \text{Mat}_{m,n}$. Equations for these varieties were given in [8]. We recall the standard permutation combinatorics needed to describe them.

The *graph* of a partial permutation matrix M_w is an $m \times n$ grid with a \bullet symbol in the entries where M_w has a 1 and blank spaces elsewhere. The *Rothe diagram* of M_w , denoted $D(w)$, consists of all boxes in $[m] \times [n]$ not weakly below or right of a \bullet in the graph of M_w . The *essential set* $E(w)$ of M_w is comprised of the maximally southeast boxes of each connected component of $D(w)$, i.e., $E(w) = \{(i, j) \in D(w) : (i, j+1), (i+1, j) \notin D(w)\}$.

Definition 6.5. The *Coxeter length* of w is the size of its Rothe diagram, $\ell(w) := \#D(w)$. The *row descent* positions of M_w , denoted $\text{Desc}_{\text{row}}(w)$, consists of row indices i such that the rightmost box in row i of $D(w)$ is strictly right of the rightmost box in row $i+1$. Similarly, the *column descent* positions of M_w is the set $\text{Desc}_{\text{col}}(w)$ of column indices j such that the bottom-most box in row j of $D(w)$ is strictly below the bottom-most box in row $j+1$.

Remark 6.6. By [8, Equation 3.4], any $M_w \in \text{Mat}_{m,n}$ is indexed by a unique permutation $\bar{w} \in \mathfrak{S}_{m+n}$ with $\ell(\bar{w}) = \ell(w)$. Indeed, M_w is the northwest $m \times n$ submatrix of the *permutation matrix* in $\text{Mat}_{m+n, m+n}$ with 1s in positions $(i, \bar{w}(i))$ and 0s elsewhere. The definitions above for partial permutation matrices agree with the corresponding definitions for the indexing permutation \bar{w} . In particular, $\text{Desc}_{\text{row}}(w) = \text{Desc}(\bar{w})$ and $\text{Desc}_{\text{col}}(w) = \text{Desc}(\bar{w}^{-1})$.

Example 6.7. Figure 5 depicts M_w and $D(w)$ for $w = 61\infty 7$. Here, $\ell(w) = 16$, $\text{Desc}_{\text{row}}(w) = \{1, 3\}$ whereas $\text{Desc}_{\text{col}}(w) = \{5\}$. Referring to Remark 6.6, $\bar{w} = 61(10)7234589(11)(12)(13)$.

We now state a concrete description of matrix Schubert varieties. Make the identification $\mathbb{C}[\text{Mat}_{m,n}] = \mathbb{C}[z_{ij} : 1 \leq i \leq m, 1 \leq j \leq n]$ where z_{ij} is the (i, j) -coordinate function.

Theorem 6.8 ([8, Proposition 3.3]). $\mathfrak{X}_w \subset \text{Mat}_{m,n}$ is the set of $m \times n$ matrices M such that the rank of the northwest $i \times j$ submatrix of M has rank $\leq r_w(i, j)$.

Let $Z = (z_{ij})_{1 \leq i \leq m, 1 \leq j \leq n}$ be the generic $m \times n$ matrix and set Z_{ij} to be the northwest $i \times j$ submatrix of Z . Then the defining ideal of $\mathfrak{X}_w \subset \text{Mat}_{m,n}$ is the Schubert determinantal ideal

$$(20) \quad I_w := I(\mathfrak{X}_w) = \langle \text{rank } r_w(i, j) + 1 \text{ minors of } Z_{ij}, (i, j) \in E(w) \rangle.$$

This ideal is prime. Under this embedding $\mathfrak{X}_w \subseteq \text{Mat}_{m,n}$ has codimension $\ell(w)$.

By definition, each \mathfrak{X}_w is a **B**-variety. They are therefore also **T**-varieties by restriction. The **T**-character of \mathfrak{X}_w (in the guise of the multigraded Hilbert series) has been extensively studied in [17, 18]. Our point of departure from [8, 17, 18] begins by observing that each \mathfrak{X}_w is also a $\mathbf{L}_{\mathbf{I}, \mathbf{J}}$ -variety for appropriate choices of **I** and **J**.

Proposition 6.9. The matrix Schubert variety \mathfrak{X}_w is $\mathbf{L}_{\mathbf{I}, \mathbf{J}}$ -stable with respect to the right action $(g, g') \cdot A = g^{-1}A(g')^T$ whenever $\text{Desc}_{\text{row}}(w) \subset \mathbf{I}$ and $\text{Desc}_{\text{col}}(w) \subset \mathbf{J}$.

Proof. By restriction, it is enough to show that $\mathbf{L} = \mathbf{L}_{\mathbf{I}, \mathbf{J}}$ acts on \mathfrak{X}_w in the case that

$$\mathbf{I} = \{0\} \cup \text{Desc}_{\text{row}}(w) \cup \{m\} = \{i_0 < i_1 < \dots < i_r\}$$

and

$$\mathbf{J} = \{0\} \cup \text{Desc}_{\text{col}}(w) \cup \{n\} = \{j_0 < j_1 < \dots < j_s\}.$$

Let $I \in \mathbf{L}$ be the identity and $A \in \text{Mat}_{m,n}$. Of course, $I \cdot A = A$; it is straightforward to check that for $(g, g'), (h, h') \in \mathbf{L}$, $(g, g') \cdot ((h, h') \cdot A) = ((h, h') \cdot (g, g')) \cdot A$, so one has a right action on $\text{Mat}_{m,n}$. Clearly this matrix-multiplication action is rational.

It remains to check that this action restricts to \mathfrak{X}_w . To see this, first fix $1 \leq k \leq r$ and let

$$(21) \quad g = (I_{i_1-i_0}, I_{i_2-i_1}, \dots, \tilde{g}, \dots, I_{i_r-i_{r-1}}),$$

be the block matrix where I_a is the $a \times a$ identity matrix and $\tilde{g} \in GL_{i_k-i_{k-1}}$. Let $A \in \mathfrak{X}_w$ and, for any (i, j) , let $A_{(i,j)}$ denote the northwest $i \times j$ submatrix of A . By (20), it suffices to show that, given $\mathbf{e} = (e_1, e_2) \in E(w)$, $\text{rank}(g \cdot A)_{\mathbf{e}} \leq r_w(e_1, e_2)$. Indeed, if $e_1 \leq i_{k-1}$, then $(g \cdot A)_{\mathbf{e}} = A_{\mathbf{e}}$ and the result follows. Thus, we may assume $e_1 > i_{k-1}$. Then

$$(g \cdot A)_{\mathbf{e}} = \begin{bmatrix} I_{i_{k-1}} & 0 & 0 \\ 0 & \tilde{g}^{-1} & 0 \\ 0 & 0 & I_{i_{e_1}-i_k} \end{bmatrix} A_{\mathbf{e}} := \tilde{G} A_{\mathbf{e}},$$

where \tilde{G} is the indicated $e_1 \times e_1$ block-diagonal matrix. Since \tilde{G} has full rank,

$$\text{rank}((g \cdot A)_{\mathbf{e}}) = \text{rank}(\tilde{G} A_{\mathbf{e}}) \leq \text{rank}(A_{\mathbf{e}}) \leq r_w(e_1, e_2),$$

as desired. Similarly, fix $1 \leq k \leq s$ and let

$$(22) \quad g' = (I_{j_1-j_0}, \dots, \tilde{g}', \dots, I_{j_s-j_{s-1}}),$$

where $\tilde{g}' \in GL_{j_k - j_{k-1}}$. If $e_2 \leq j_{k-1}$, then $(g' \cdot A)_e = A_e$ and the result follows. Assume $j_{k-1} < e_2$ and let

$$\tilde{G}' = \begin{bmatrix} I_{j_{k-1}} & 0 & 0 \\ 0 & (\tilde{g}'^{-1})^T & 0 \\ 0 & 0 & I_{j_{e_2 - j_k}} \end{bmatrix}.$$

As before,

$$\text{rank}((g \cdot A)_e) = \text{rank}(A_e \tilde{G}') \leq \text{rank}(A_e) \leq r_w(e_1, e_2).$$

Given $(h, h') \in \mathbf{L}$, h factorizes into a product of matrices of the form (21), and h' factorizes into matrices of the form (22). Thus, the claim the right action restricts holds. \square

As explained in Section 2.2 (see (13)), by Proposition 6.9, $\mathbb{C}[\mathfrak{X}_w]$ is a $\mathbf{L}_{\mathbf{I}\mathbf{J}}$ -representation for any $\mathbf{I} \supseteq \text{Desc}_{\text{row}}(w)$ and $\mathbf{J} \supseteq \text{Desc}_{\text{col}}(w)$. We now check that \mathfrak{X}_w is $\mathbf{L}_{\mathbf{I}\mathbf{J}}$ -crystal closed in order to apply Theorem 1.11 to compute the $\mathbf{L}_{\mathbf{I}\mathbf{J}}$ -character of $\mathbb{C}[\mathfrak{X}_w]$.

6.2. Standard monomials of \mathfrak{X}_w and proof of Theorem 1.14. Fix an *antidiagonal term order* \prec on $S = \mathbb{C}[z_{11}, \dots, z_{mn}]$, i.e., one that picks the antidiagonal term of a minor. One example is pure lexicographic order obtained by setting $z_{ab} \succ z_{cd}$ if $a < c$, or $a = c$ and $b > d$. This is Knutson–Miller’s Gröbner basis theorem:

Theorem 6.10 ([17, Theorem B]). *Fulton’s generators (20) for I_w form a Gröbner basis with respect to \prec .*

Any monomial m in the z_{ij} can be naturally identified with a nonnegative integer matrix, via its exponent vector. Identifying m with the corresponding matrix, Theorem 6.10 describes the standard monomials of \mathfrak{X}_w in terms of matrices, as follows:

Corollary 6.11. *$m \in \text{Std}_{\prec}(S/I_w)$ if and only if for any Fulton generator g of I_w from (20), the product of the entries of m along the main antidiagonal of g is 0.*

The standard monomials of any \mathbf{B} -stable variety $\mathfrak{X} \subset \text{Mat}_{m,n}$ are described in terms of the standard monomials of matrix Schubert varieties. This follows immediately from work of Knutson on Frobenius splittings [16], although it is not explicitly stated there.¹

Proposition 6.12 (cf. [16]). *Let $\mathfrak{X} \subseteq \text{Mat}_{m,n}$ be a \mathbf{B} -stable variety. Write $\mathfrak{X} = \bigcup_{i=1}^k \mathfrak{X}_{w^{(i)}}$ as a union of matrix Schubert varieties (by Corollary 6.4). Then the set of standard monomials for \mathfrak{X} , with respect to \prec , is $\text{Std}_{\prec}(\mathfrak{X}) = \bigcup_{i=1}^k \text{Std}_{\prec}(S/I_{w^{(i)}})$.*

Proof. Let $I = \bigcap_{i=1}^k I_{w^{(i)}}$ be the ideal of \mathfrak{X} in S . By [16, Section 7.2], $\text{init}_{\prec}(I) = \bigcap_{i=1}^k \text{init}_{\prec}(I_{w^{(i)}})$. The claim follows since, by definition, $\text{Std}_{\prec}(\mathfrak{X}) = \text{Std}_{\prec}(S/I)$ are the monomials in $\text{init}_{\prec}(I)^c$ taken with coefficient 1. \square

We next prove Theorem 1.14 for the case $\mathfrak{X} = \mathfrak{X}_w$ is a matrix Schubert variety.

Theorem 6.13. *Let $\mathfrak{X}_w \subseteq \text{Mat}_{m,n}$ where $\text{Desc}_{\text{row}}(w) \subseteq \mathbf{I}$ and $\text{Desc}_{\text{col}}(w) \subseteq \mathbf{J}$. Then \mathfrak{X}_w is $\mathbf{L}_{\mathbf{I}\mathbf{J}}$ -bicrystalline.*

¹See also [2] for Bertiger’s construction of a Gröbner basis for arbitrary \mathbf{B} -stable varieties.

Proof. By Proposition 6.9, \mathfrak{X}_w is $L_{I|J}$ -stable. It remains to show that \mathfrak{X}_w is $L_{I|J}$ -bicrystal closed. We focus first on the I -filtered row operators e_i^{row} and f_i^{row} . Since e_i^{row} and f_i^{row} are inverses whenever their outputs are not \emptyset by Lemma 4.12, the $L_{I|J}$ -bicrystal closed claim follows from the (slightly stronger) statement that if $m \notin \text{Std}_{<}(S/I_w)$ (identified with a matrix in $\text{Mat}_{m,n}(\mathbb{Z}_{\geq 0})$), then $e_i^{\text{row}}(m) \notin \text{Std}_{<}(S/I_w)$ for all i and $f_i^{\text{row}}(m) \notin \text{Std}_{<}(S/I_w)$ for $i \notin \text{Desc}_{\text{row}}(w)$. We prove this latter statement.

Since $m \notin \text{Std}_{<}(S/I_w)$, by Corollary 6.11, there exists a Fulton generator g for I_w such that the product of all entries of m along the antidiagonal A_g of g is nonzero. Let $R \subseteq [m]$ and $C \subseteq [n]$ be the row and column indices, respectively, of the minor g .

First, we argue that $e_i^{\text{row}}(m) \notin \text{Std}_{<}(S/I_w)$ by constructing a Fulton generator g' for I_w such that the product of all entries of $e_i^{\text{row}}(m)$ along $A_{g'}$ is positive.

Case e1: ($i, i+1 \notin R$) Here, e_i^{row} does not affect any of the entries of A_g in m . Take $g' = g$.

Case e2: ($i \in R, i+1 \notin R$) All entries of A_g in $e_i^{\text{row}}(m)$ are only larger (by at most 1) in comparison to the same entry in m , so we may again take $g' = g$.

Case e3: ($i \notin R, i+1 \in R$) If e_i^{row} does not affect the entry of A_g in row $i+1$, take $g' = g$. Otherwise, we may take g' to be the minor defined by row indices $R' = (R \setminus \{i+1\}) \cup \{i\}$ and column indices C (which is also a Fulton generator for I_w by (20)).

Case e4: ($i, i+1 \in R$) Let b be as in Definition 4.24. If $m_{i+1,b}$ does not lie on the antidiagonal A_g or $m_{i+1,b} \geq 2$, then we may take $g' = g$. Otherwise, since we assume $e_i^{\text{row}}(m) \neq \emptyset$, the entry $m_{i+1,b} = 1$ corresponds to an unmatched "(" in $\text{bracket}_i(\text{row}(m))$. Let b' be the first column to the right of b in C , so $(i, b') \in A_g$. None of the "(" in $\text{bracket}_i(\text{row}(m))$ associated to $m_{i,b'} > 0$ match with this aforementioned "(" . In particular, the leftmost "(" associated to $m_{i,b'}$ matches with a "(" associated to $m_{i+1,c'} > 0$ for some $b < c' < b'$. Take g' to be the minor defined by row indices R and column indices $C' = (C \setminus \{b\}) \cup \{c'\}$ (which is also a Fulton generator for I_w by (20)).

Similarly, we show that $f_i^{\text{row}}(m) \notin \text{Std}_{<}(S/I_w)$ when $i \notin \text{Desc}_{\text{row}}(w)$ by constructing a Fulton generator g'' for I_w such that the product of entries of $f_i^{\text{row}}(m)$ along $A_{g''}$ is positive.

Case f1: ($i, i+1 \notin R$) Same argument as Case e1, take $g'' = g$.

Case f2: ($i \in R, i+1 \notin R$) If f_i^{row} does not affect the entry of A_g in row i , let $g'' = g$. Otherwise, let g'' be the minor that uses the rows $R'' = (R \setminus \{i\}) \cup \{i+1\}$ and columns C (which is also a Fulton generator of I_w provided $i \notin \text{Desc}_{\text{row}}(w)$ by (20)).

Case f3: ($i \notin R, i+1 \in R$) Same argument as Case e2, take $g'' = g$.

Case f4: ($i, i+1 \in R$) We use left-right "flipped" version of Case e4. Let a be as in Definition 4.24. If $m_{i,a}$ does not lie on A_g or $m_{i,a} \geq 2$, then we may take $g'' = g$. Otherwise, since we assume $f_i^{\text{row}}(m) \neq \emptyset$, the entry $m_{i,a} = 1$ corresponds to an unmatched "(" in $\text{bracket}_i(\text{row}(m))$. Let a' be the first column to the left of a in C , so $(i+1, a') \in A_g$. None of the "(" in $\text{bracket}_i(\text{row}(m))$ associated to $m_{i+1,a'} > 0$ match with this aforementioned "(" . In particular, the rightmost "(" associated to $m_{i+1,a'}$ matches with a "(" associated to $m_{i,c''} > 0$ for some $a' < c'' < a$. Take g'' to be the minor defined by row indices R and column indices $C'' = (C \setminus \{a\}) \cup \{c''\}$ (which is a Fulton generator of I_w by (20)).

The statements for f_j^{col} and e_j^{col} hold by taking transposes of all matrices involved. \square

Proof of Theorem 1.14. Let $\mathfrak{X} \subseteq \text{Mat}_{m,n}$ be \mathbf{B} -stable. By Corollary 6.4, $\mathfrak{X} = \bigcup_{i=1}^k \mathfrak{X}_{w^{(i)}}$ is a union of matrix Schubert varieties. By Proposition 6.9, any $\mathbf{L}_{\mathbf{I}|\mathbf{J}}$ satisfying the conditions in the theorem statement acts on $\mathfrak{X}_{w^{(i)}}$ and hence on \mathfrak{X} . Furthermore, \mathfrak{X} is $\mathbf{L}_{\mathbf{I}|\mathbf{J}}$ -bicrystal closed by Proposition 6.12 combined with Theorem 6.13. \square

7. FINAL REMARKS

Abusing notation, write an $(\mathbf{I}|\mathbf{J})$ -filtered partition-tuple $(\underline{\lambda}|\underline{\mu})$ as a sequence of non-negative integers $(\lambda_1, \dots, \lambda_m | \mu_1, \dots, \mu_n)$ such that $\lambda_i \geq \lambda_{i+1}$ if $i \notin \mathbf{I}$ and $\mu_j \geq \mu_{j+1}$ if $j \notin \mathbf{J}$.

Let us return to the basic case $\mathfrak{X} = \text{Mat}_{m,n}$. Here $c_{\underline{\lambda}|\underline{\mu}} = c_{\underline{\lambda}|\underline{\mu}}^{\text{Mat}_{m,n}}$, as in Example 1.12. We set the convention that if $M = [m_{i,j}] \in \text{Mat}_{m,n}(\mathbb{Z}_{\geq 0})$, then $m_{i,j} = 0$ if $i > m$ or $j > n$. We can characterize highest-weight matrices of shape $(\underline{\lambda}|\underline{\mu})$ as follows:

Proposition 7.1. *The coefficients $c_{\underline{\lambda}|\underline{\mu}}$ count the number of $M = [m_{i,j}] \in \text{Mat}_{m,n}(\mathbb{Z}_{\geq 0})$ that are lattice points of the polytope $\mathcal{P}_{\underline{\lambda}|\underline{\mu}}$ defined by the highest-weight conditions*

$$(23) \quad \sum_{k=j}^n m_{i+1,k} \leq \sum_{k=j}^n m_{i,k+1} \text{ for all } i \notin \mathbf{I} \text{ and } j \in [n],$$

$$(24) \quad \sum_{k=i}^m m_{k,j+1} \leq \sum_{k=i}^m m_{k+1,j} \text{ for all } j \notin \mathbf{J} \text{ and } i \in [m],$$

the shape conditions

$$(25) \quad \sum_{j=1}^n m_{i,j} = \lambda_i \text{ for all } i \in [m],$$

$$(26) \quad \sum_{i=1}^m m_{i,j} = \mu_j \text{ for all } j \in [n],$$

and the nonnegativity constraints $m_{i,j} \geq 0$ for all $i \in [m], j \in [n]$.

Proof. $M = [m_{i,j}] \in \text{Mat}_{m,n}(\mathbb{Z}_{\geq 0})$ has highest weight if $e_i^{\text{row}}(M) = 0 = e_j^{\text{col}}(M)$ for all $i \notin \mathbf{I}$ and $j \notin \mathbf{J}$. Writing out the parenthesis-matching rules for these matrix crystal operators numerically expresses the highest-weight conditions as (23) and (24).

The highest weight matrices M are exactly those sent to some highest-weight tableau-tuple by $\text{filterRSK}_{\mathbf{I}|\mathbf{J}}$. The shape of a highest-weight matrix M is therefore uniquely determined by its weight, i.e., the collection of its row and column sums. Thus a highest-weight matrix M has shape $(\underline{\lambda}|\underline{\mu})$ if and only if it satisfies (25) and (26). \square

Example 7.2 (Contingency tables). Let $\mathbf{I} = \{0\} \cup [m]$ and $\mathbf{J} = \{0\} \cup [n]$, so $\mathbf{L}_{\mathbf{I}|\mathbf{J}} = \mathbf{T}$ is the $(m+n)$ -torus acting on $\text{Mat}_{m,n}$. Then $\text{filterRSK}_{\mathbf{I}|\mathbf{J}}$ computes the \mathbf{T} -character of $\mathbb{C}[\text{Mat}_{m,n}]$ by mapping the exponent matrix $M \in \text{Mat}_{m,n}(\mathbb{Z}_{\geq 0})$ of each monomial to the exponent vector $\text{cwt}_{\mathcal{M}_{m,n}}(M)$ of its torus weight. Here, there are no $(\mathbf{I}|\mathbf{J})$ -filtered crystal moves, so (23) and (24) are trivial. Thus, (25) and (26) say $c_{\underline{\lambda}|\underline{\mu}}$ counts *contingency tables*, i.e., $M \in \text{Mat}_{m,n}(\mathbb{Z}_{\geq 0})$ whose i th row sums to λ_i and j th column sums to μ_j for all $i \in [m]$ and $j \in [n]$.

Example 7.3 (The classical Cauchy identity). Let $\mathbf{I} = \{0, m\}$ and $\mathbf{J} = \{0, n\}$. Then $\text{filterRSK}_{\mathbf{I}|\mathbf{J}}$ is the usual RSK map sending each $M = [m_{i,j}] \in \text{Mat}_{m,n}(\mathbb{Z}_{\geq 0})$ to a tableau-pair $(P|Q)$. Applying (23) with $j = n$, we see that $m_{i+1,n} = m_{i,n+1}$ for all $i \in [m-1]$. But $m_{i,n+1} = 0$ for

all such i since these entries lie entirely outside of M , so in fact $m_{i+1,n} = 0$ for $i \in [m-1]$. Similarly, applying (24) with $i = m$ shows that $m_{m,j+1} = 0$ for all $j \in [n-1]$. Iterating this argument shows that $m_{i+k,n+1-k} = m_{n+1-k,j+k} = 0$ for all $i \in [m-1]$, $j \in [n-1]$, and $k \in \mathbb{Z}_{\geq 0}$, so any matrix M satisfying (23) and (24) must be northwest-triangular.

Similar iterative arguments on the inequalities (or equivalently, in terms of brackets) on the non-zero entries of M show that all entries on each antidiagonal must be equal. In other words, the matrices satisfying the highest-weight conditions (23) and (24) are of

the form $\begin{bmatrix} a & b & c & d & e \\ b & c & d & e & 0 \\ c & d & e & 0 & 0 \\ d & e & 0 & 0 & 0 \\ e & 0 & 0 & 0 & 0 \end{bmatrix}$. Now, it is easy to see that further imposing (25) and (26) shows that $c_{\lambda|\mu} = 1$ if $\lambda = \mu$ and 0 otherwise, by Proposition 7.1. This recovers the classical Cauchy identity (1) and proves Theorem 3.14.

Example 7.4 (A polytopal Littlewood–Richardson rule). Let $\mathbf{I} = \{0, t, m\}$ for some $0 < t < m$ and let $\mathbf{J} = \{0, n\}$. Write $(\underline{\lambda}|\underline{\mu}) = (\lambda^{(1)}, \lambda^{(2)}|\mu)$ for an $(\mathbf{I}|\mathbf{J})$ -filtered tableau-tuple. Then $c_{\underline{\lambda}|\underline{\mu}}$ is the Littlewood–Richardson coefficient $c_{\lambda^{(1)}, \lambda^{(2)}}^{\mu}$ (for partitions of the right size). Thus, Proposition 7.1 specializes to a polytopal rule for Littlewood–Richardson coefficients.

Proposition 7.1 extends to $c_{\underline{\lambda}|\underline{\mu}}^{\mathfrak{X}}$ where $\mathfrak{X} \subseteq \text{Mat}_{m,n}$ is any $\mathbf{L}_{\mathbf{I}|\mathbf{J}}$ -bicrystalline variety.

Proposition 7.5. *Let $\mathfrak{X} \subseteq \text{Mat}_{m,n}$ be $\mathbf{L}_{\mathbf{I}|\mathbf{J}}$ -bicrystalline. Let $\mathcal{P}_{\underline{\lambda}|\underline{\mu}}$ be the polytope in Proposition 7.1, and let $\mathcal{P}^{\mathfrak{X}}$ be the set of lattice points corresponding to elements of $\text{Std}_{<}(S/I(\mathfrak{X}))$. Then $c_{\underline{\lambda}|\underline{\mu}}^{\mathfrak{X}}$ counts lattice points in $\mathcal{P}_{\underline{\lambda}|\underline{\mu}}^{\mathfrak{X}} = \mathcal{P}^{\mathfrak{X}} \cap \mathcal{P}_{\underline{\lambda}|\underline{\mu}}$.*

Proof. By Theorem 1.11, $\text{filterRSK}_{\mathbf{I}|\mathbf{J}}$ computes the $\mathbf{L}_{\mathbf{I}|\mathbf{J}}$ -character of \mathfrak{X} . By Proposition 7.1, the coefficient $c_{\underline{\lambda}|\underline{\mu}} = c_{\underline{\lambda}|\underline{\mu}}^{\text{Mat}_{m,n}}$ counts the integer points in $\mathcal{P}_{\underline{\lambda}|\underline{\mu}}$. The desired coefficient $c_{\underline{\lambda}|\underline{\mu}}^{\mathfrak{X}}$ counts only the points in this polytope corresponding elements of $\text{Std}_{<}(S/I(\mathfrak{X}))$. \square

Remark 7.6. Proposition 7.5 is not a polytopal rule for $c_{\underline{\lambda}|\underline{\mu}}^{\mathfrak{X}}$, since the set $\mathcal{P}^{\mathfrak{X}}$ is not generally a polytope. However, if $\text{init}_{<}(I(\mathfrak{X}))$ is squarefree, one can give a serviceable description of $\mathcal{P}^{\mathfrak{X}}$ as a union of polytopes using a prime decomposition of $\text{init}_{<}(I(\mathfrak{X}))$. This case includes all \mathbf{B} -stable varieties by the description of their initial ideals given previously.

Example 7.7 (Classical determinantal varieties). Let $\mathbf{I} = \{0, m\}$ and $\mathbf{J} = \{0, n\}$. Let $\mathfrak{X}_k \subseteq \text{Mat}_{m,n}$ be the variety of rank $\leq k$ matrices. It is known that a Gröbner basis for $I(\mathfrak{X}_k)$ with respect to antidiagonal term order consists of the $k+1$ -order minors of the generic $m \times n$ matrix (this is an instance of Theorem 6.10). The same highest-weight and contingency table conditions hold as in Example 7.3, but if $k \neq m$ or $k \neq n$ then there are also nontrivial standard monomial conditions. The standard monomials of \mathfrak{X}_k correspond to matrices with at least one 0 on each antidiagonal after the k th (where the first antidiagonal is the northwest corner). Combining with the highest-weight and contingency table restrictions from before yields this known Cauchy-type identity:

$$(27) \quad \chi_{\mathbb{C}[\mathfrak{X}_k]} = \sum_{\lambda, \ell(\lambda) \leq k} s_{\lambda}(\mathbf{x}) s_{\lambda}(\mathbf{y}).$$

ACKNOWLEDGEMENTS

We thank Andrew Hardt for a helpful conversation about [18] and Shiliang Gao for pointing us to the motivating reference [29] on standard monomials and Hilbert series.

AS was supported by a Susan C. Morisato IGL graduate student scholarship and an NSF graduate fellowship. AY was supported by a Simons Collaboration grant. The authors were partially supported by an NSF RTG in Combinatorics (DMS 1937241)

REFERENCES

- [1] Abhyankar, Shreeram Shankar. *Combinatoire des tableaux de Young, varietes determinantielles et calcul de fonctions de Hilbert*. Rend Sere. Mat. Univers. Politech. Torino 42 (1984), 65–88.
- [2] Bertiger, Anna. *Generating the ideals defining unions of Schubert varieties*. Int. Math. Res. Not. IMRN 2015, no. 21, 10847–10858.
- [3] Bump, Daniel; Schilling, Anne. *Crystal bases. Representations and combinatorics*. World Scientific Publishing Co. Pte. Ltd., Hackensack, NJ, 2017. xii+279 pp.
- [4] Cox, David; Little, John; O’Shea, Donal. *Using algebraic geometry*. Graduate Texts in Mathematics, 185. Springer-Verlag, New York, 2005. xii+572 pp.
- [5] Danilov, V. I.; Koshevoi, G. A.. *Arrays and the combinatorics of Young tableaux*. Russ. Math. Surv 60 (2005), 269–334.
- [6] de Concini, C.; Procesi, C. *A characteristic free approach to invariant theory*. Advances in Math. 21 (1976), no. 3, 330–354.
- [7] Doubilet, Peter; Rota, Gian-Carlo; Stein, Joel. *On the foundations of combinatorial theory. IX. Combinatorial methods in invariant theory*. Studies in Appl. Math. 53 (1974), 185–216
- [8] Fulton, William. *Flags, Schubert polynomials, degeneracy loci, and determinantal formulas*. Duke Math. J. 65 (1992), no. 3, 381–420.
- [9] W. Fulton, *Young tableaux. With applications to representation theory and geometry*. London Mathematical Society Student Texts, 35. Cambridge University Press, Cambridge, 1997. x+260 pp.
- [10] Galigo, Andre. *Computations of some Hilbert functions related with Schubert calculus*. In: E. Casas-Alvero, G.E. Welters and S. Xambó-Descamps, Eds., *Algebraic Geometry, Sitges (Barcelona)*, Lecture Notes in Math., Vol. 1124. Springer, New York (1983), 79–97.
- [11] Ghorpade, Sudhir. *Young bitableaux, lattice paths, and Hilbert functions*. J. Statistical Planning and Inference 54 (1996), 55–66.
- [12] Harris, Joe. *Algebraic geometry. A first course*. Graduate Texts in Mathematics, 133. Springer-Verlag, New York, 1992. xx+328 pp.
- [13] Herzog, Jürgen; Trung, NgôViêt. *Gröbner bases and multiplicity of determinantal and pfaffian ideals*. Adv. Math. (1) 96 (1992), 1–37.
- [14] Hodges, Reuven; Yong, Alexander. *Coxeter combinatorics and spherical Schubert geometry*. J. Lie Theory 32 (2022), no. 2, 447–474.
- [15] Howe, Roger. *Perspectives on invariant theory: Schur duality, multiplicity-free actions and beyond*. The Schur lectures (1992) (Tel Aviv), 1–182, Israel Math. Conf. Proc., 8, Bar-Ilan Univ., Ramat Gan, 1995.
- [16] Knutson, Allen. *Frobenius splitting, point-counting and degeneration*, preprint, 2009. arXiv:0911.4941v1.
- [17] Knutson, Allen; Miller, Ezra. *Gröbner geometry of Schubert polynomials*. Ann. of Math. (2) 161 (2005), no. 3, 1245–1318.
- [18] Knutson, Allen; Miller, Ezra. *Subword complexes in Coxeter groups*. Adv. Math. 184 (2004), no. 1, 161–176.
- [19] Knutson, Allen; Miller, Ezra; Yong, Alexander. *Gröbner geometry of vertex decompositions and of flagged tableaux*. J. Reine Angew. Math. 630 (2009), 1–31.
- [20] Knutson, Allen; Tao, Terence. *The honeycomb model of $GL_n(\mathbb{C})$ tensor products. I. Proof of the saturation conjecture*. J. Amer. Math. Soc. 12 (1999), no. 4, 1055–1090.
- [21] Kwon, Jae-Hoon. *Crystal graphs and the combinatorics of Young tableaux*. Handbook of algebra. Vol. 6, 473–504, Handb. Algebr., 6, Elsevier/North-Holland, Amsterdam, 2009.
- [22] Miller, Ezra; Sturmfels, Bernd. *Combinatorial commutative algebra*. Graduate Texts in Mathematics, 227. Springer-Verlag, New York, 2005. xiv+417 pp.
- [23] Milne, James. *Algebraic groups*. Cambridge Studies in Advanced Mathematics, 170. Cambridge University Press, Cambridge, 2017, 585 pp.
- [24] Monical, Cara; Tokcan, Neriman; Yong, Alexander. *Newton polytopes in algebraic combinatorics*. Selecta Math. (N.S.) 25 (2019), no. 5, Paper No. 66, 37 pp.

- [25] Procesi, Claudio. Lie groups. An approach through invariants and representations. Universitext. Springer, New York, 2007. xxiv+596 pp.
- [26] Shimozono, Mark. Crystals for Dummies. <https://www.aimath.org/WWN/kostka/crysdumb.pdf>, 2005.
- [27] Stanley, Richard P. Enumerative combinatorics. Vol. 2. With a foreword by Gian-Carlo Rota and appendix 1 by Sergey Fomin. Cambridge Studies in Advanced Mathematics, 62. Cambridge University Press, Cambridge, 1999. xii+581 pp.
- [28] Steinberg, Robert. Lectures on Chevalley groups. Notes prepared by John Faulkner and Robert Wilson. Yale University, New Haven, CT, 1968. iii+277 pp.
- [29] Sturmfels, Bernd. Gröbner bases and Stanley decompositions of determinantal rings. Math. Z. 205 (1990), 137–144. <https://doi.org/10.1007/BF02571229>
- [30] van Leeuwen, Marc. Double crystals of binary and integral matrices. Elec. J. of Combinatorics 13 (2006), no. 1, R86.
- [31] Weyman, Jerzy. *Cohomology of vector bundles and syzygies*. Cambridge Tracts in Mathematics, 149. Cambridge University Press, Cambridge, 2003. xiv+371 pp.
- [32] Zelevinsky, Andrei. Littlewood-Richardson semigroups. New perspectives in algebraic combinatorics (Berkeley, CA, 1996/97), 337–345, Math. Sci. Res. Inst. Publ., 38, Cambridge Univ. Press, Cambridge, 1999.

DEPT. OF MATHEMATICS, U. ILLINOIS AT URBANA-CHAMPAIGN, URBANA, IL 61801, USA

Email address: price29@illinois.edu, astelzer@illinois.edu, ayong@illinois.edu